

# SHING LING<sup>®</sup>

INDUSTRIAL SEWING MACHINE

## General Catalog

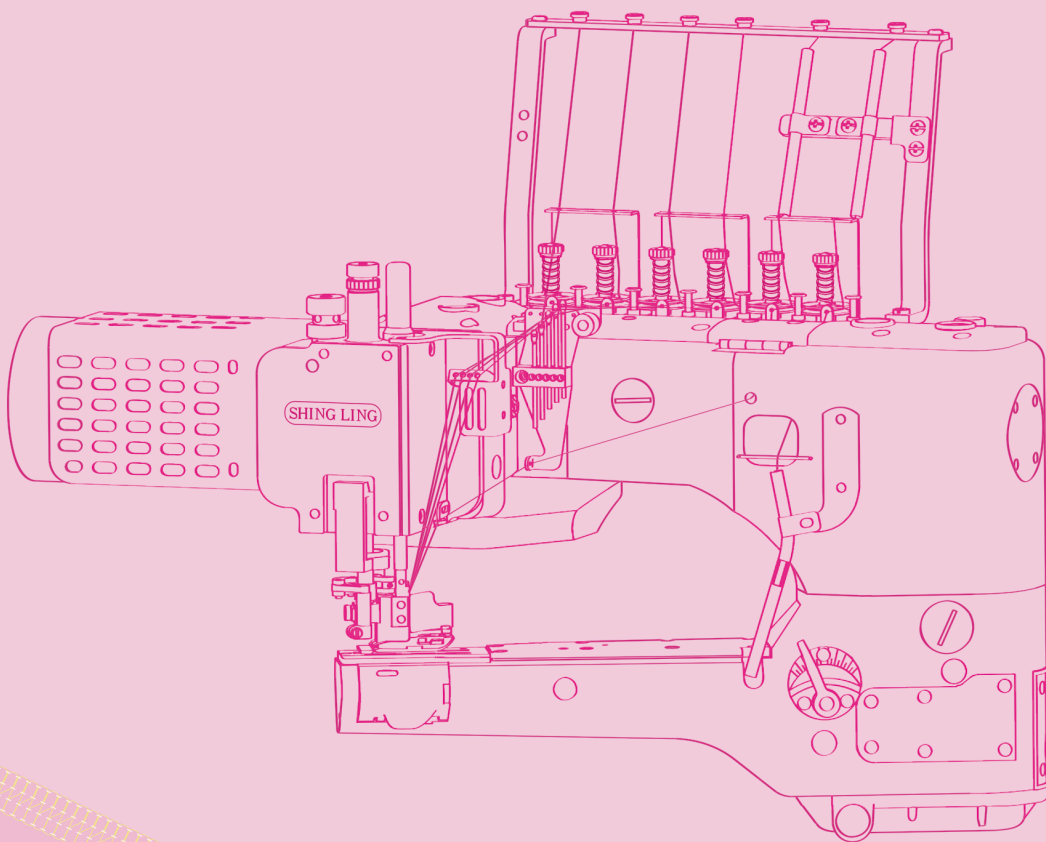

*Shing Ling, where the sewing begins!*

SHING LING<sup>®</sup>



星菱縫機股份有限公司  
SHING LING SEWING MACHINE CO., LTD.



地 址：新北市林口區工二工業區工二路10號

No.10, Kung 2<sup>nd</sup> Rd., Kung 2<sup>nd</sup> Industrial Park, Linkou Dist., New Taipei City 244, Taiwan

負責人：徐石淵 Johnson Hsu

電 話：886-2-2601-8866(Rep)、2601-5588

傳 真：886-2-2602-3399、2603-6677

E-MAIL: shingling@shingling.com.tw URL: www.shingling.com.tw

## 星菱縫紉機(寧波)有限公司

地 址：寧波市鎮海區駱駝工業區榮吉路182號

電 話：86-574-8657-6688

傳 真：86-574-8656-5999

星菱(集團)公司創立於西元1989年，是生產工業用縫紉機的專業跨國企業。徐董事長深耕產業達48年之久，鑑於企業優質化經營，自2010年導入自動化生產設備，復於2013和2014年再擴大引進日本最先進的精密綜合加工機，奠定集團在台灣成為研發及製造中心，使零件的生產、成品的組裝、都能全程嚴格控管品質，進而提供客戶全系列高品質工業用縫紉機。

星菱縫機的研發策略是提供符合成衣廠所需的縫紉機及車縫技術。近年來本公司多項新產品更榮獲各類大獎並申請各國專利。例如SL-701P(703P)系列手臂型雙切(單切)全密封雙差動搭配外掛式凸輪四針六線併縫機廣泛運用於針織布料及潛水衣併縫、VG-999ES/TF系列超細筒型三針五線綳縫機(附上送裝置)適用於小尺寸及童裝、VG-999S-N700及VG-999S-N700/TF高速細筒型綳縫機(附上送裝置)最先進高產能全自動車下襪及袖口專用機、SL-2800系列縱筒加長型綳縫機等，都備受世界各地客戶的好評及肯定。

品質第一；客戶至上。是我們不變的堅持。以臻至工藝，打造國際品牌；以負責態度，永續經營是我們核心理念。在此誠摯殷盼海內外各界對星菱縫機公司的惠予支持及不吝指導。

Established in 1989, we, Shing Ling Sewing Machine Co., Ltd., are one of the most leading industrial sewing machine manufacturers in Taiwan producing a full range of superior high quality sewing machines. Due to our in-house manufacturing from every component to assembly by cutting-edged equipment and strictly quality control, we ensure our worldwide customers the highly-reliable machines with the most competitive price and rapid delivery.

We have been newly-developing interlock and flatseaming machines such as SL-701P(703P) serial fully-sealed type 4-needle 6-thread feed-off-the-arm machines with built-out looper take-up device for a neatly-finished flatseaming on knitwear and neoprene diving suit, VG-999ES/TF series 3-needle 5-thread extremely small cylinder interlock machines with top feeder best-suited to small tubular children wear, high production of fully automatic computer-controlled VG-999S-N700-TF series small cylinder-bed Interlock machines with top feeder applicable to sleeve and bottom hemming on sportswear, T-shirt, polo shirt, and our unique-design SL-2800 series 3-needle 5-thread feed-up-the-arm (long arm type) Interlock machines for long stitches of seam covering and converted to 4-needle 6-thread covering stitches for two fabrics joining work. All the machines have awarded national price and reserved patents.

No Quality No Sale is our consistent marketing strategy. We will continue devoting ourselves to the industry and creating customers' maximum interests. Please log on our web-site [www.shingling.com.tw](http://www.shingling.com.tw) for the details of our machines and contact us today. Any enquiries from you will receive our immediate attention.

**SL-700 手臂型四針六線雙切併縫機**

4-needle 6-thread feed-off-the-arm Interlock stitch machine for flatseaming with dual differential feed ratio regulator.



SL-700 Series FLATSEAMER .....	1
SL-700 series Adjustable mounting base...	4
SL-700 Series Options/Device .....	6
SL-700 Series Presser Foot .....	7
ATK-1 and ATK-2 For SL-700 Series .....	8
SL-701-452/G0/DS/VD/PLA .....	9
SL-701-452/G1/DS/VD/PLA/ZBR .....	9
SL-701-460/G1/DS/VD/PLE.....	10
SL-703-460/G3/DS/VD/PLA/EFV/RP... ..	10
SL-703-452/G3/DS/VD/PLA .....	11
SL-703-452/G2/DS/VD/PLA/SLS .....	11
SL-703-460/G3/DS/VD/PLA/EFV/RP... ..	12
SL-703-460/G3/DS/VD/PLE/IPIP .....	12
SL-703-452/G3/DS/VD/PLA .....	13
SL-713-460/G0/DS/VD/PLA .....	13
SL-703-460/G3/DS/VD/PLA/RP/EFV... ..	14
SL-713-480/G0 .....	15
SL-703P-GX/452/G3/DS/VD/PLE .....	15
SL-701-G1 潛水衣專用 For neoprene materials. ..	16

**FW-777 縱筒型三針五線雙面飾綳縫機**

Feed-up-the-arm 3-needle 5-thread Interlock Machine with Differential Feed Ratio (with compact servo motor for needle position)



FW-777 Series .....	17
FW-777 .....	18
FW-777-603/SM .....	18

**SL-2700 高速縱筒型二針四線鎖鏈綳縫機**

High Speed Feed-up-the-arm 2-needle 2-looper double chain stitch machine for tape attaching



SL-2700-AST/EST .....	19
SL-2700-264-SL-SM-ATK .....	20

**SL-2800 高速縱筒型三針五線雙面飾綳縫機**

High Speed Feed-up-the-arm 3-needle 5-thread Interlock Machine with Compact Servo Motor and Automatic Thread Trimmer



SL-2800-356/SM .....	22
SL-2800-356/SM .....	23
SL-2800-356/SM/EST .....	24

**VG-999 Series 高速橫筒型三針五線雙面飾綳縫機**

High Speed 3-needle 5-thread Cylinder-bed Interlock Machine with Direct-drive Servo Motor, Top and Under Thread Trimmer

VG-999 Series .....	26
---------------------	----

**VG-999 Series 高速橫筒型三針五線雙面飾綳縫機**  
High Speed 3-needle 5-thread Cylinder-bed Interlock Machine with Direct-drive Servo Motor, Top and Under Thread Trimmer



VG-999 Series Options/Device .....	27
Features of VG-999 series.....	28
VG-999-AST-DS .....	31
VG-999ES-AST-TF-DS .....	32
VG-999S-N700-AST-TF-DS .....	34
VG-999S-N700-AST-DS.....	35
VG-999-AST/EST/DS/CF/ZBR.....	37
VG-999-356/EST/ZBR/DS .....	38
VG-999SB-AST/EST/DS .....	39
VG-999-R500-AST-RP .....	40

**VG-888A Series 高速橫筒型三針五線綳縫機**  
3-needle 5-thread Cylinder-bed Interlock Machine with Direct-drive Servo Motor, Electric Top and Under Thread Trimmer



VG-888A Series .....	41
VG-888A Series Options/Device.....	42
VG-888A-N600/TF/AST/SAH-II.....	44
VG-888A-TF/AST.....	45
VG-888A-N600/AST.....	45
VG-888A-N600-TF/AST.....	46
VG-888A-CF Series .....	46
VG-888A-RP .....	47
VG-888A-EST .....	47
VG-888A-L200 .....	48
VG-888A-L300/AST .....	48

**VG-888S 高速細筒型三針五線綳縫機**  
Small Cylinder-bed Interlock Machine with Direct-drive Servo Motor, Top and Under Thread Trimmer



VG-888S Series.....	49
888S Series Options/Device.....	50
VG-888S/AST .....	51
VG-888S/EST.....	51
VG-888S-RP.....	52
VG-888S-TF/AST Series .....	52

**FG-666 平床型三針五線雙面飾綳縫機**  
3-needle 5-thread Flat-bed Interlock Machine with Top and Under Thread Trimmer

FG-666 Series .....	54
---------------------	----



FG-666/EST .....	56
FG-666-264-SL .....	56
FG-666-FQ Series.....	57

**FG-799 平床型三針五線雙面飾綳縫機附右切刀修布裝置**  
3-needle 5-thread Flat-bed Interlock Machine with Right-hand Knife Fabric Trimmer



FG-797 .....	57
FG-798-TF-SAS .....	58
FG-799 .....	58

**SL-1790 高速電子平頭鎖眼機**  
Computer-controlled High-speed Lockstitch Buttonholing Machine



SL-1790.....	59
SL-1790 Standard Sewing Shape List ..	60
Specifications.....	61

**SL-1905A-SS 全自動直驅式高速電子雙用機**  
Automatic Direct-drive Type High Speed Computer Controlled Double Function Machine.



SL-1905A-SS .....	62
SL-1900 series .....	62
SL-1900A-SS .....	63
SL-1903A.....	63

**SL-807 Series 直驅式高速包縫機**  
Direct-drive High-speed Overlock Sewing Machine



SL-807D-4 .....	64
SL-808T-4.....	65

**SL-9500-D3 直驅式單針自動切線平縫機**  
Direct drive high speed one needle lockstitch sewing machine



SL-9500-D3 .....	66
------------------	----

**SL-8800N 折景花樣車**  
SL-8800 Pleating(Ruffling) Machine



SL-8800-997 / 998 .....	66
-------------------------	----

## SL-700 Series FLATSEAMER

### 手臂型四針六線雙切併縫機

4-needle 6-thread feed-off-the-arm Interlock stitch machine for flatseaming with dual differential feed ratio regulator.



## PERFORMANCE COMPARISON TABLE

701 - 4 52 - G0 / DS / VD / PLA / EFV

1. 機種 Model		4. 切布裝置 Fabric trimmer		5. 功能輔助件 Options/Device	
701	Short presser foot with single fabric trimmer	G0	單切 . 無溝 One side fabric trimmer	DS	直驅馬達 Direct-drive Servo Motor
701P		G1	單切 . 有溝 One side fabric trimmer	VD	吸布屑裝置 Venturi device
703	Short presser foot with double fabric trimmer	G2	雙切 Both side fabric trimmer	PLA	氣動抬壓腳 Auto lifter by air
703P		G2-H	雙切寬刀 Both side fabric trimmer	PLE	電動抬壓腳 Auto lifter by electric
713	Long presser foot with double fabric trimmer	G2N	雙切 Both side fabric trimmer	GX	雙差動裝置 Dual differential feed ratio regulator
713P		G3	雙切 Both side fabric trimmer	AT	直式線切裝置 Pneumatic chain cutter
		G4	雙切 Both side fabric trimmer	EFV	吸入式切線裝置 Pneumatic chain cutter
		G5	無切刀輪型壓腳 (長) Presser foot with caster (Long)	ATK	感應式電子切刀 Photo-sensor controlled chain cutter
		G6	無切刀輪型壓腳 (短) Presser foot with caster (Short)	RP	電子式後拖輪 Electric rear puller
		GU	雙切 . 平接 Both side fabric trimmer and butt seam	RPM	機械式後拖輪 Mechanic rear puller
		703A-G4	斷差 1mm 1mm stepped	SL	3/8" 貼條 . 雙切 3/8" tape attaching
		703B-G4	斷差 1.5mm 1.5mm stepped	SLS	1/4" 貼條 . 雙切 1/4" tape attaching
		713-G0	雙切 . 長壓腳 Both side fabric trimmer, Long presser foot	IPIP	排品 . 雙切 Piping
		713-G1	雙切 . 長壓腳 . 貼條 Long presser foot, tape attaching	TKA	蕾絲織帶及滾條切刀 Lace band and tape cutter

## SL-701-G0/G1-452-460

For Light to Medium Material  
適合薄到中厚布料單切併縫

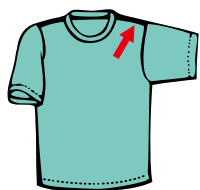

G0 G1

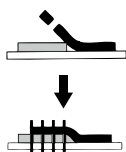

(單切)  
(Single Cut)



## SL-701-G0/G1-452-460

For Crotch Seaming of Men's Briefs and Heavy Material  
褲底過骨及厚料併縫

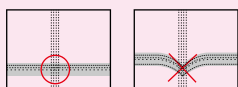
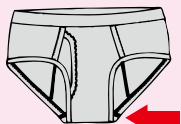

G1

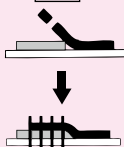

(單切)  
(Single Cut)



## SL-703-G3-452-460

For Fully Overlapping  
雙切雙色布料密合併縫

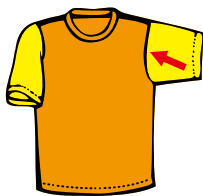

G3

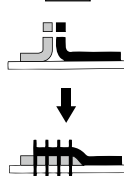

(雙切)  
(Double Cut)



## SL-713-G1-460-SL

For Folded Taping  
雙切貼條併縫



G1

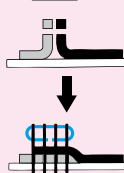

(雙切)  
(Double Cut)

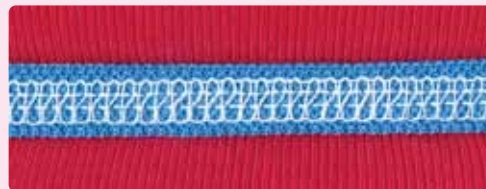

## SL-703-G2-452-SLS

For Reinforced Taping  
雙切補強帶貼條併縫



G2

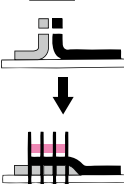

(雙切)  
(Double Cut)



## SL-703-G3-452-IPIP

For Unfolded Piping  
無折邊飾條併縫

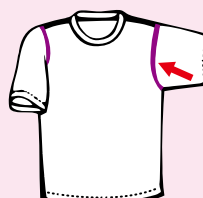

G3

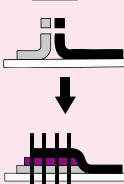

(雙切)  
(Double Cut)

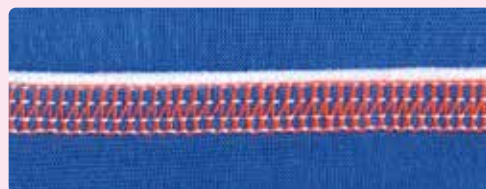

## SL-703-G2-452/460

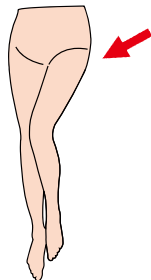

For Sewing Pantyhose, Leggings, etc.  
適用於薄料. 褲襪. 保暖機車縫

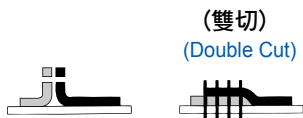

## SL-703U-452/460

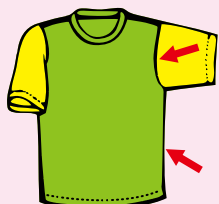

For Light to Medium Material with two fabrics attaching  
適用於薄至中厚針織布料  
平接縫專用

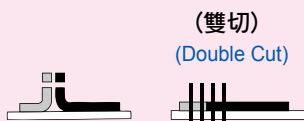

## SL-703A/703B-G4/452/460

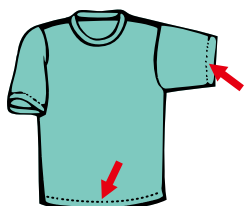

For Light to Medium Material with Different Thickness Overlapping  
斷差壓腳  
適用於薄至中厚針織布料  
左、右厚度不同. 接縫專用

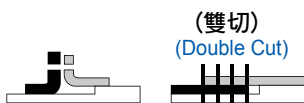

## SL-701-452-G1 . SL-713-452/460/470/480-G0



適用於中厚針織布、潛水衣  
長距離彎角圓弧及小裁片單(雙)切併縫。  
雙切:適用於各式中厚布料及潛水衣併縫作業。  
Applicable to medium-heavy-weight material, e.g. fleece and neoprene diving suit.

701.703-G1

短壓腳

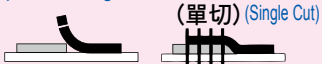

713-G0

長壓腳



## SL-701-460-G0-1 SL-703-460-G2-1

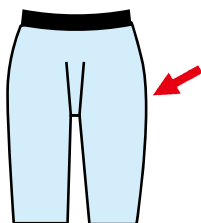

For Leggings with Double Fabric Overlapping  
適用於保暖褲  
雙層泡綿布料車縫

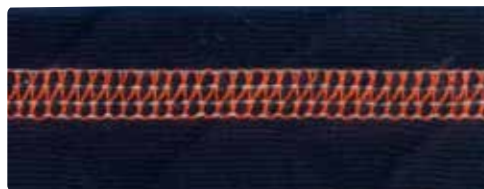
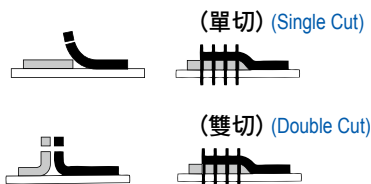

## SL-703GX-552-G3

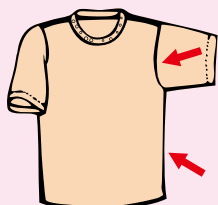

(5針) 適用於薄至中厚  
針織布料車縫



**SL-700 series****可調式底座**

Adjustable mounting base

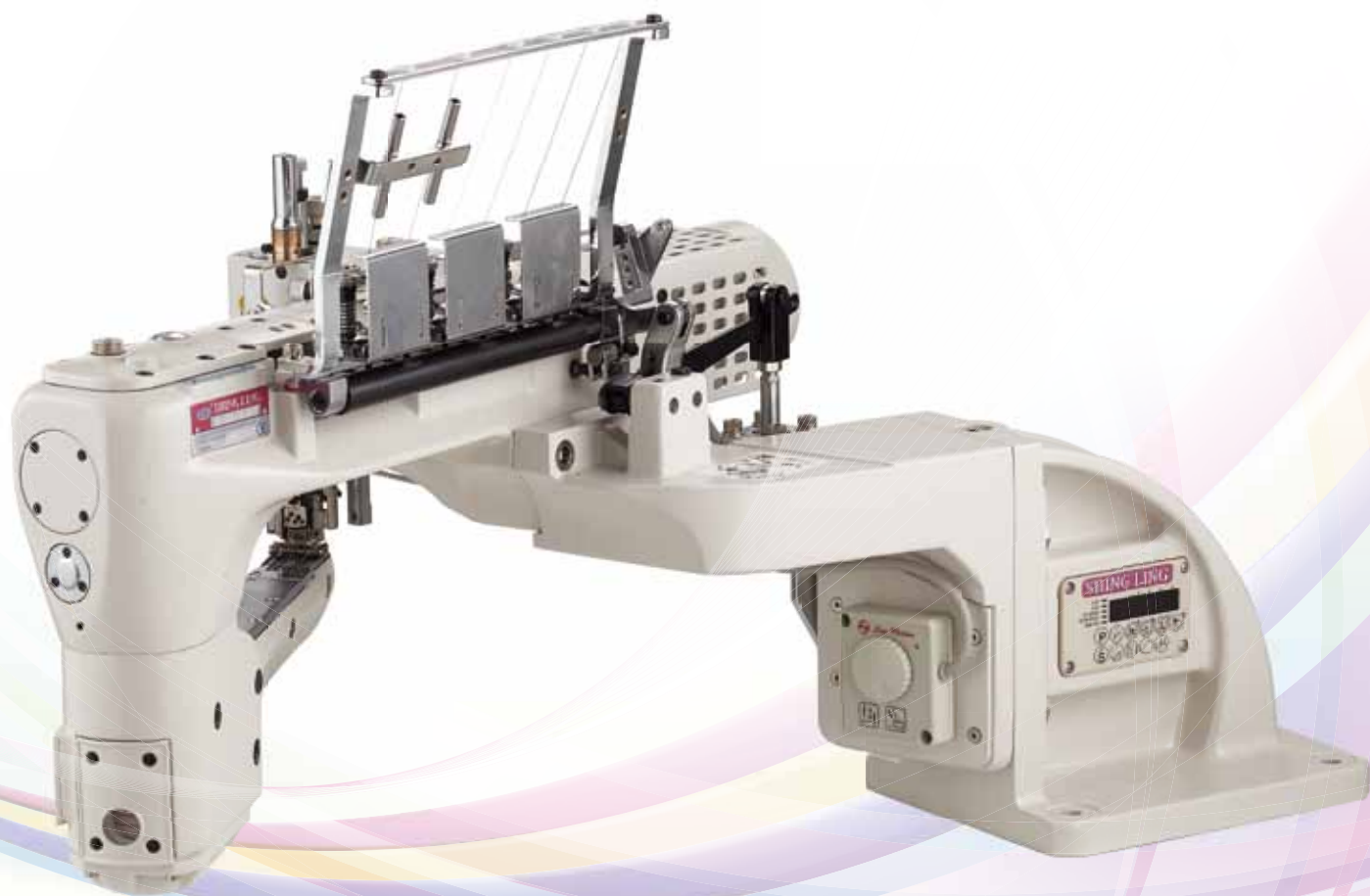

- ★ **新型700系列支撐座**  
User friendly & ergonomic design
- ★ **可調式升降底座**  
Height adjustable
- ★ **控制面版更易調控維修**  
Easy-maintenance control panel
- ★ **可依據使用者車縫高度調整**  
Comfortable operation
- ★ **電子手輪裝置**



# 升降底座調整方式

Regulate method of adjustable mounting base.

1. 鬆開A處螺絲×4。  
Loosen the screws at A (4 pieces)
2. 用6號內六角扳手調整B處螺絲。  
Adjust the screw at B with no.6 hex wrench.
3. 確認機器高度後，請鎖緊A處螺絲×4。  
After confirming the height of the machine, please lock the screws at A (4 pieces)

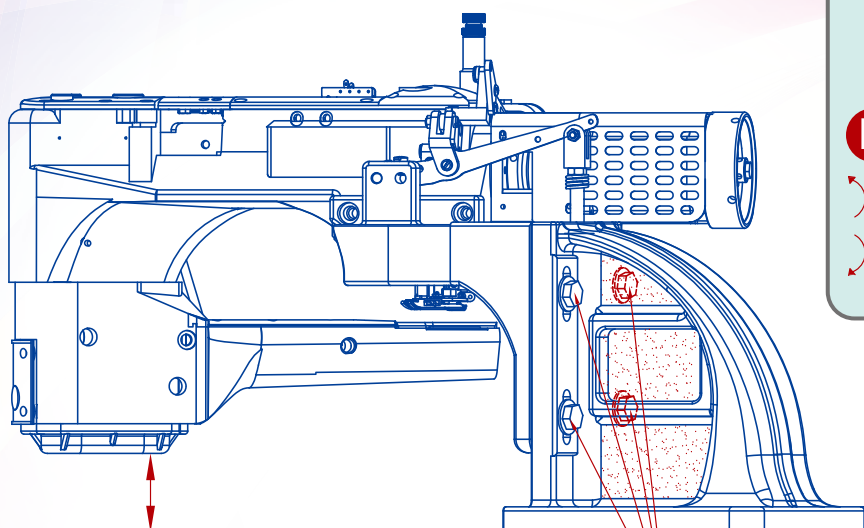

桌板  
Table 0cm

A

鬆開A處螺絲×4，上下間隙可調整約3cm。  
Loosen the screws at A (4 pieces), the gap can be adjusted up and down about 3cm.

調整高低螺絲  
Adjust the height  
of the screw.

B

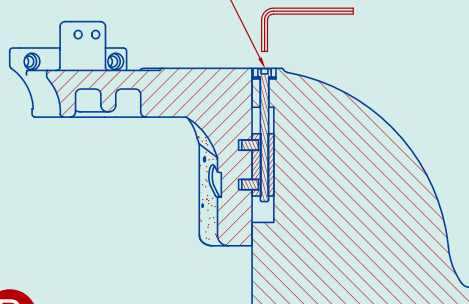

B

- 逆時針轉會下降  
Counterclockwise rotation will go down.
- 順時針轉會上升  
Clockwise rotation will go up.

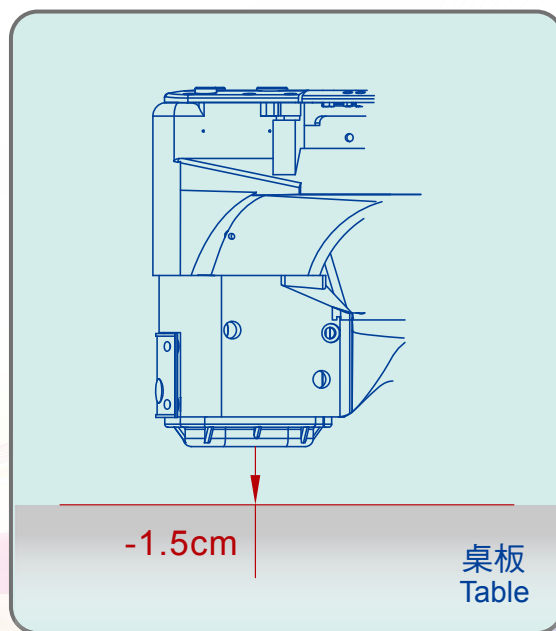
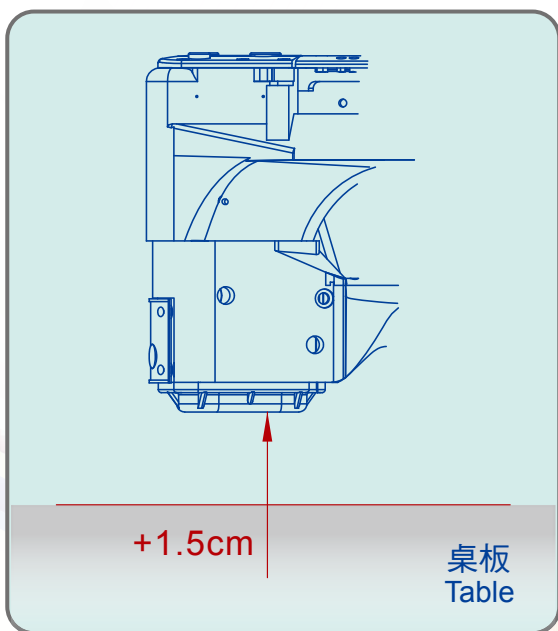

可依據個人車縫需求調整高度±1.5cm  
Can be adjusted according to individual sewing  
needs height ± 1.5cm.

## SL-700 系列四針六線輔助件明細表

### SL-700 Series Options/Device

<b>DS</b>	直驅馬達 Direct-drive Servo Motor	<b>VD</b>	吸布屑裝置 Venturi device	<b>PLA</b>	氣動抬壓腳 Air type lifter
					
<b>PLE</b>	電動抬壓腳 Auto lifter by electric	<b>GX</b>	雙差動裝置 Differential feed ratio regulator	<b>EHW</b>	電子手輪 Electric Hand Wheel
					
<b>EFV</b>	吸入式切線裝置 Pneumatic chain cutter	<b>ATK</b>	電眼式自動切刀裝置 Photo-sensor controlled thread chain and tape cutter	<b>AT</b>	直式線切裝置 Pneumatic chain cutter
					
<b>RP</b>	電子式後拖輪 Electric rear puller	<b>RPM</b>	機械式後拖輪 Mechanic rear puller	<b>SL</b>	3/8 貼條 . 雙切 3/8 tape attaching
					
				<b>SLS</b>	1/4 貼條 . 雙切 1/4 tape attaching
					
<b>IPIP</b>	排品 . 雙切 Piping	<b>552</b>	552 雙切布樣 5-needle with 5.2mm gauge	<b>RB120</b>	
				吸風馬達 Electric venturi device 	

## SL-700 系列四針六線壓腳圖一覽

### SL-700 Series Presser Foot

<b>G0</b>	單切 . 無溝 One side fabric trimmer	<b>G1</b>	單切 . 有溝 One side fabric trimmer	<b>G2</b>	雙切 Both side fabric trimmer
					
<b>G2-H</b>	雙切 . 寬刀 Both side fabric trimmer	<b>G3</b>	雙切 Both side fabric trimmer	<b>G4</b>	雙切 Both side fabric trimmer
					
<b>GU</b>	雙切 . 平接 Butt seam	<b>703A-G4</b>	斷差 1mm 1mm Stepped	<b>703B-G4</b>	斷差 1.5mm 1.5mm Stepped
					
<b>713-G0</b>	雙切 . 長壓腳 Long foot with both side fabric trimmer	<b>713-G1</b>	雙切 . 長壓腳 . 貼條 Long foot for tape attaching	<b>700 series</b>	粗細送布尺 coarse & fine feed dog
					

# ATK-1 and ATK-2 For SL-700 Series

手臂型四針六線雙切併縫機 ( 附光電感應切線、切帶裝置 )

4-needle, 6-thread, Feed-off-the-arm Interlock Flatseaming Machine with photo-sensor controlled thread chain and tape cutter

ATK-1

**NEW**

ATK-2



- 採用先進光電感應自動切刀，能精確調整前後切線、切帶長度。  
The length of thread chain and tape at the beginning and ending can be precisely cut by the photo-sensor controlling.
- 同步切線、切帶功能，適用於一般四針併縫、肩帶加強、排品及貼條作業。  
Thread chain and tape can be cut simultaneously. The cutter is best suited for standard flatseaming, tape attaching on shoulder for reinforcement, piping and so on.
- 全自動電子感應切刀能提高產能與品質  
Fully automatic electronic induction cutter can improve productivity and quality.

# SL-701-452/G0/DS/VD/PLA

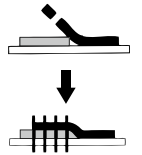
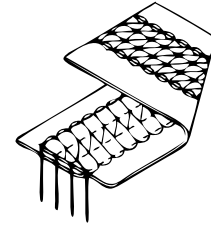

Model No.	Gauge	針數	線數	Edge Trimming	Material	Illustration	差動	腳高	RPM
機型	針位組	針數	線數	修布刀	車縫布料	車縫樣式	差動	腳高	轉速
SL-701-452/G0/DS/VD/PLA	452 460	4	6	Single 單切	Light to Medium 薄至中厚		1:0.7 1:1.5	6mm	2800

# SL-701-452/G1/DS/VD/PLA/ZBR

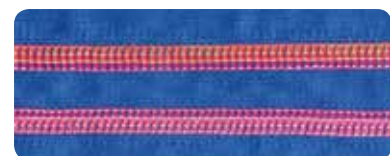
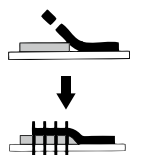
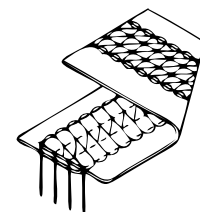
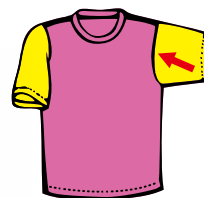

適用於伸縮布料如：萊卡布、韻律裝、T恤、Polo 衫等各式雙色線併縫

Dual Colors Decorative Stitches applicable to T-shirts, Sportswear, Polo shirt, etc.

Model No.	Gauge	針數	線數	Edge Trimming	Material	Illustration	差動	腳高	RPM
機型	針位組	針數	線數	修布刀	車縫布料	車縫樣式	差動	腳高	轉速
SL-701-452/G1/DS/VD/PLA	452 460	4	7	Single 單切	Light to Medium 薄至中厚		1:0.7 1:1.5	6mm	2800

# SL-701-460/G1/DS/VD/PLE

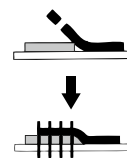
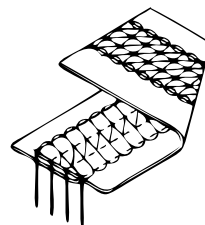
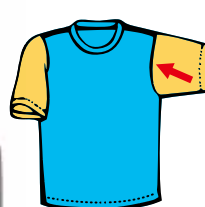

Model No.	Gauge	針數	線數	Edge Trimming	Material	Illustration	差動	腳高	RPM
機型	針位組	針數	線數	修布刀	車縫布料	車縫樣式	差動	腳高	轉速
SL-701-460/G1/DS/VD/PLE	452 460	4	6	Single 單切	Light to Medium 薄至中厚		1:0.7 1:1.5	6mm	2800



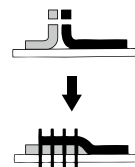
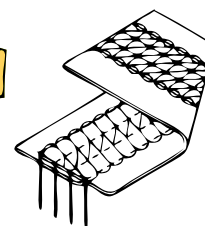
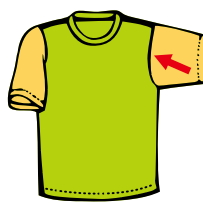

# SL-703-460/G3/DS/VD/PLA/EFV/RP

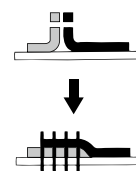
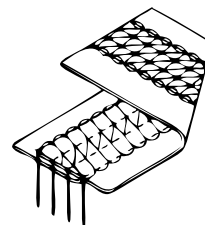
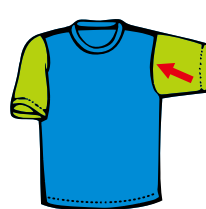

Model No.	Gauge	針數	線數	Edge Trimming	Material	Illustration	差動	腳高	RPM
機型	針位組	針數	線數	修布刀	車縫布料	車縫樣式	差動	腳高	轉速
SL-703-460/G1/DS/VD/PLA/EFV/RP	452 460	4	6	Single 單切	Light to Medium 薄至中厚		1:0.7 1:1.5	6mm	2800





# SL-703-452/G3/DS/VD/PLA

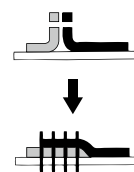
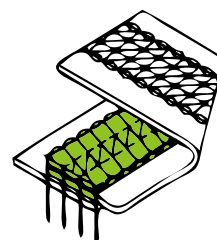

Model No.	Gauge			Edge Trimming	Material	Illustration			RPM
機型	針位組	針數	線數	修布刀	車縫布料	車縫樣式	差動	腳高	轉速
SL-703-452/G3/DS/VD/PLA	452 460	4	6	Double 雙切	Light to Medium 薄至中厚		1:0.7 1:1.5	6mm	2800

# SL-703-452/G2/DS/VD/PLA/SLS



Model No.	Gauge			Edge Trimming	Material	Illustration			RPM
機型	針位組	針數	線數	修布刀	車縫布料	車縫樣式	差動	腳高	轉速
SL-703-452/G2/DS/VD/PLA/SLS	452 460	4	6	Double 雙切	Light to Medium 薄至中厚		1:0.7 1:1.5	6mm	2800

# SL-703-460/G3/DS/VD/PLA/EFV/RP

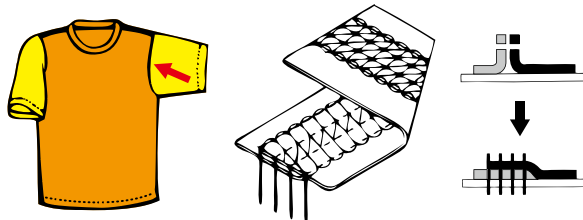

Model No.	Gauge	針數	線數	Edge Trimming	Material	Illustration	差動	腳高	RPM
機型	針位組	針數	線數	修布刀	車縫布料	車縫樣式	1:0.7 1:1.5	6mm	轉速
SL-703-460/G3/DS/VD/PLA/EFV/RP	452 460	4	6	Double 雙切	Light to Medium 薄至中厚				2800

# SL-703-460/G3/DS/VD/PLE/IPIP

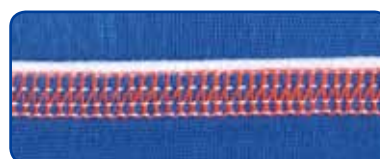
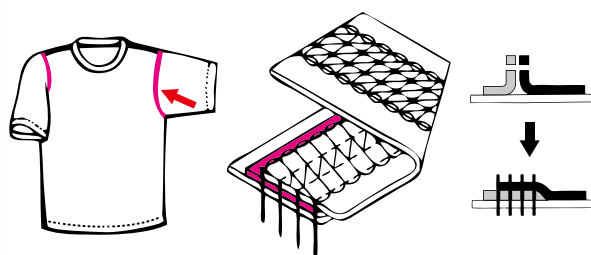

Model No.	Gauge	針數	線數	Edge Trimming	Material	Illustration	差動	腳高	RPM
機型	針位組	針數	線數	修布刀	車縫布料	車縫樣式	1:0.7 1:1.5	6mm	轉速
SL-703-460/G3/DS/VD/PLE/IPIP	452 460	4	6	Double 雙切	Light to Medium 薄至中厚				2800



# SL-703-452/G3/DS/VD/PLA

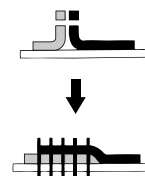
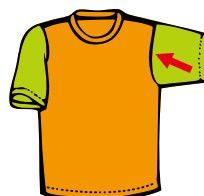

Model No.	Gauge			Edge Trimming	Material	Illustration			RPM
機型	針位組	針數	線數	修布刀	車縫布料	車縫樣式	差動	腳高	轉速
SL-703-452/G3/DS/VD/PLA	452	4	6	Double 雙切	Light to Medium 薄至中厚		1:0.7 ~ 1:1.5	6mm	2800

# SL-713-460/G0/DS/VD/PLA



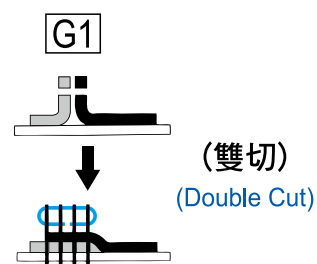

For Folded Taping  
雙切貼條併縫



Model No.	Gauge			Edge Trimming	Material	Illustration			RPM
機型	針位組	針數	線數	修布刀	車縫布料	車縫樣式	差動	腳高	轉速
SL-713-460/G0/DS/VD/PLA	460	4	6	Double 雙切	Light to Medium 薄至中厚		1:0.7 ~ 1:1.5	6mm	2800

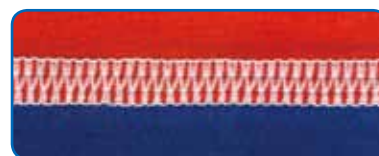
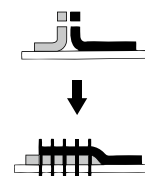
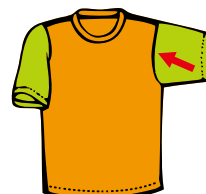



# SL-703-460/G3/DS/VD/PLA/RP/EFV

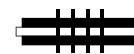

Model No.	Gauge			Edge Trimming	Material	Illustration			RPM
機型	針位組	針數	線數	修布刀	車縫布料	車縫樣式	差動	腳高	轉速
SL-703-460/G3/DS/VD/PLA/RP/EFV	452 460	4	6	Double 雙切	Light to Medium 薄至中厚		1:0.7 ~ 1:1.5	6mm	2800

# SL-713-480/G0



Model No.	Gauge			Edge Trimming	Material	Illustration			RPM
機型	針位組	針數	線數	修布刀	車縫布料	車縫樣式	差動	腳高	轉速
SL-713-480/G0	452 460 470 480	4	6	無 without	Light to Medium 薄至中厚		1:0.7 ~ 1:1.5	6mm	2800

# SL-703P-GX/452/G3/DS/VD/PLE

## 手臂型四針六線雙切併縫機 ( 附雙差動送布齒裝置 )

4-needle 6-thread feed-off-the-arm Interlock stitch machine for flatseaming with dual differential feed ratio regulator

### 全密封型

Fully oil-sealed design without any oil spot  
防污染. 衣物乾淨整潔

專利 台灣M405445.M405444.  
號碼 M405443.M395003.  
M328462.M311697.M307022

ISO 9001:2008 Rev. CE



右邊主送布齒，調整手把，往刻度9為細針，刻度1為粗針。  
Turn the regulator upward for shorter stitch length ;  
turn it downward for longer stitch length.

外調式針距調整各種針距、可輕易微調、各類布種可適用。  
The micro-adjustment of dual differential feed ratio can receive a higher  
quality of sewn product. It also obtains free puckering from light to  
medium materials such as silk, lycra, fleece, etc.



四針六線雙切型。配合新式陶瓷過線裝置、線距更為穩定、美觀。  
The ceramic eyeleting design receives a consistent and beautifully-  
finished interlock flatseaming stitches.

DS/直驅式伺服馬達驅動及獨創雙差動設計，是四針六線併縫，高質量、  
高產能的機種。  
Equipped with direct-drive servo motor ensures lower power consumption,  
less noisy and no vibration to achieve a highly efficient sewing work.

Model No.	Gauge	針數	線數	Edge Trimming	Material	Illustration	差動	腳高	RPM
機型	針位組	針數	線數	修布刀	車縫布料	車縫樣式	差動	腳高	轉速
SL-703P-GX/ 452/DS/VD/PLE	452 460	4	6	Double 雙切	Light to Medium 薄至中厚		1:0.7 1:1.5	6mm	2800

## SL-701-G1 潛水衣專用

4-needle 6-thread Curved-shaped Feed-off-the-arm Interlock Stitch Machine for Flatseaming; Unique Design for a Variety of Neoprene Materials.

**NEW**



弧形手臂設計，適用於潛水衣及溯溪褲等…  
四針曲線併縫

Curve-shaped machine arm is specialized in curve flatseaming stitches on diving suit, wading trousers and any neoprene materials.

手機套、保溫杯套樣品

Stitch sample of cell phone and thermos bottle pouch

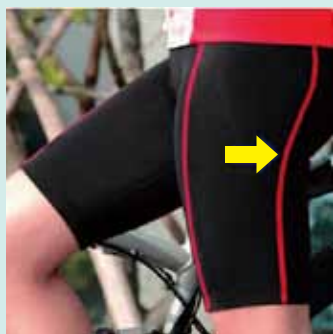

701.703-G1  
短壓腳

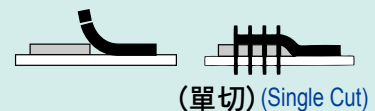

適用於中厚針織布、潛水衣長距離彎角圓弧及小裁片單(雙)切併縫。

雙切：適用於各式中厚布料及潛水衣併縫作業。

Applicable to medium-heavy-weight material, e.g. fleece and neoprene diving suit.

Model No.	Gauge	針位組	針數	線數	Edge Trimming	Material	Illustration	差動	腳高	RPM
機型	針位組	針數	線數	修布刀	車縫布料	車縫樣式	5 5	mm	轉速	
SL-701-452/G1/DS/VD/PLA	452 460	4	6	Single 單切	Light to Medium 薄至中厚		1:0.7 1:1.5	6mm	2800	

### FW-777 Series

#### 縱筒型三針五線雙面飾綳縫機 ( 附小馬達 )

Feed-up-the-arm 3-needle 5-thread Interlock Machine with Differential Feed Ratio (with compact servo motor for needle position)

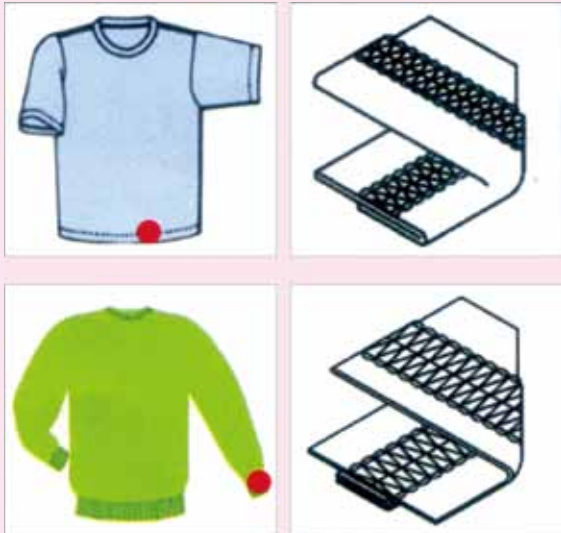

適用於各式休閒服折袖口、折下擺等。  
Applicable to sleeve and bottom hemming on T-shirts, underwear, sports wear, etc.



適用於各種針織品、運動服壓骨車縫。  
Applicable to stitch covering on all kinds of small tubular knitwear, sports wear, etc.



適用於雙勾針鏈目縫貼條。  
Attached with tape folder on presser foot for tape attaching.

### PERFORMANCE COMPARISON TABLE

FW - 777 - 356 - 603 / SM

1. 機種 Model	
FW-777	縱筒型三針五線雙面飾綳縫機 ( 附小馬達 ) Feed-up-the-arm 3-needle 5-thread Interlock Machine
FW-777-603	縱筒型三針五線雙面飾綳縫機 ( 附小馬達 ) Feed-up-the-arm 3-needle 5-thread Interlock Machine with Differential Feed Ratio

2. 針數 No. of Needle	
2	2 針 2 needles
3	3 針 3 needles
4	4 針 4 needles

3. 針寬 Needle Gauge	
40	寬 4.0mm Width 4.0mm
48	寬 4.8mm Width 4.8mm
56	寬 5.6mm Width 5.6mm
60	寬 6.0mm Width 6.0mm
64	寬 6.4mm Width 6.4mm

4. 功能輔助件 Options/Device	
603	差動裝置 Differential feed ratio
777	無差動裝置 Without differential feed ratio
SM	伺服馬達 Compact Servo Motor
CL	離合器馬達 Clutch motor
3 合 1 3 in 1	袖口 . 下擺 . 立骨倒骨 Tape Binding, Hemming, Cover stitch
264	2 針貼條裝置 2-needle 2-lopper tape attaching

# FW-777

## 縱筒型三針五線雙面飾綳縫機

Feed-up-the-arm 3-needle 5-thread  
Interlock Machine

台灣專利號碼：175668 · 195792 · 185040  
179984 · 208723 · M296258  
大陸專利號碼：ZL 01 2 00868.0  
ZL 03 2 70528.X



# FW-777-603/SM

## 縱筒型三針五線雙面飾綳縫機 ( 附小馬達 ) 有差動齒

Feed-up-the-arm 3-needle 5-thread Interlock Machine with Differential Feed Ratio (with compact servo motor for needle position)

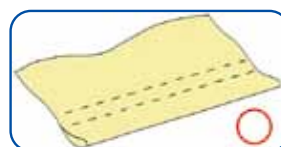

雙齒差動比，車縫不起波浪。  
Light fabric sewn smoothly by our differential feed ratio machine.

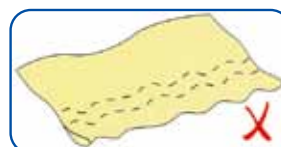

無雙齒差動比，起波浪。  
Cause puckering without differential feed ratio design.



活動式底線供給結構，可隨心所欲操作高低穿線  
New design looper take-up device for easy threading











簡易調整差動比。  
It is easy to adjust the differential feed ratio.



底線供給結構，全新密閉設計，完全不絞線。  
Securely covered take-up device is free from thread winding.



雙齒差動比，車縫不起波浪。  
There is no puckering on clothes due to the differential feed ratio design.

			 m.m.	 m.m.	 m.m.	 m.m.	 UT120GAS TXZ	 S.P.M.	AVAILABLE DEVICE
FW-777 FW-777-603/SM	2	4	4.0	1.5~5	2.5~5	6	9~11	3500	
	3	5	4.8 5.6						
	4	6	6.4						

# SL-2700-AST/EST

## 高速縱筒型三針五線雙面式綑縫機 ( 具備微型馬達設計 )

High speed Feed-up-the-arm 3-needle 5-thread Interlock Machine with compact Servo Motor and Automatic Thread Trimmer



## PERFORMANCE COMPARISON TABLE

SL-2700

- 3

56

- AST

/ EST

### 1. 機種 Model

SL2700	高速縱筒型三針五線雙面飾綑縫機 High Speed Feed-up-the-arm 3-needle 5-thread Interlock Machine with Compact Servo Motor and Automatic Thread Trimmer
SL-2700-264-SL-SM	高速縱筒型二針四線鎖鏈綑縫機 High speed Feed-up-the-arm 2-needle 4-thread Double Chain stitch Machine For Tape Attaching

### 2. 針數 No. of Needle

2	2 針 2 needles
3	3 針 3 needles
4	4 針 4 needles

### 3. 針寬 Needle Gauge

40	寬 4.0mm Width 4.0mm
48	寬 4.8mm Width 4.8mm
56	寬 5.6mm Width 5.6mm
60	寬 6.0mm Width 6.0mm
64	寬 6.4mm Width 6.4mm

### 4. 功能輔助件 Options/Device

CF	三合一功能 "3 in 1" function
CE	埋壓拷克骨、立骨功能 Bulging type seams covering
AST	氣動式自動切線裝置 ( 有上切刀組 ) Pneumatic under & top thread trimmer
DS	直驅馬達 Direct-drive Servo Motor
EWT	電動式自動切線裝置 ( 無上切刀組 ) Electric automatic under thread trimmer
EST	電動式自動切線裝置 ( 有上切刀組 ) Electric automatic top & under thread trimmer
AWT	氣動式自動切線裝置 ( 無上切刀組 ) Pneumatic under thread trimmer
SM	伺服器馬達背掛式 Compact servo motor
CL	離合器馬達 Clutch motor
ATK	自動感應切條裝置 000

## SL-2700-264-SL-SM-ATK

高速縱筒型二針四線鎖鏈綑縫機 (具備微型馬達設計)

High Speed Feed-up-the-arm 2-needle 4-thread Double Chain Stitch Machine for Tape Attaching

New

新型切條裝置

ATK



手動切刀裝置



電眼感應裝置











貼條圖樣

Sewn sample of Tape Attaching



標準貼條裝置

Tape Attaching device

									AVAILABLE DEVICE
SL-2700-264-SL-SM	2 3 4	4 5 6	4.0 4.8 5.6 6.4	1.5~5	2-4-4.6	6	UNI266AS TVXZ 4 T	4000	SM/CL





獨特粗細針按鈕設計可隨心所欲調整縫目粗細

Stitch length can be adjusted quickly as required by the smart push-button.



智慧型差動微調器可精密調整差動量

Micro-adjustment regulator makes differential feed ratio easy and precise.











雙勾針貼條裝置，適用肩、領、袖、拷克骨貼條車縫

2-needle 2-looper double chain stitch for tape attaching on shoulder, neck, sleeve, etc.



適用於各式休閒服折袖口、折下擺和各種針織品、運動服壓骨車縫。

Applicable to stitch covering and hemming work on all kinds of small tubular knitwear, sports wear, T-shirts, underwear, etc.

									AVAILABLE DEVICE
SL-2700-AST/EST	2 3 4	4 5 6	4.0 4.8 5.6 6.4	1.5~5	2.5~5	6	UY128GAS TX17	4000	AST/EST AWT/EWT SM/CL

## SL-2800-356/SM

## 高速縱筒型三針五線雙面飾綑縫機 ( 具備微型馬達設計 )

High Speed Feed-up-the-arm 3-needle 5-thread Interlock Machine with Compact Servo Motor and Automatic Thread Trimmer

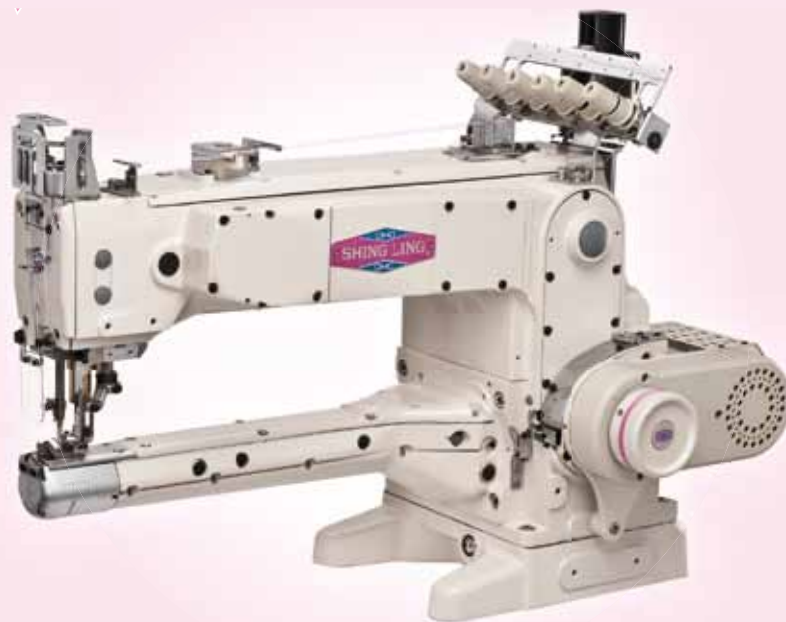

## PERFORMANCE COMPARISON TABLE

SL-2800

-

3

56

-

AST

/

EST

1. 機種  
Model

SL2800	高速縱筒型三針五線雙面式綑縫機 ( 加長型 ) High speed Feed-up-the-arm 3-needle 5-thread Interlock Machine(Long Arm)
SL-2800-SL-SM	縱筒加長型三針五線雙面飾綑縫機 High speed Feed-up-the-arm 2-needle 4-thread Double Chain stitch Machine For Tape Attaching(Long Arm)

2. 針數  
No. of Needle

2	2 針 2 needles
3	3 針 3 needles
4	4 針 4 needles

3. 針寬  
Needle Gauge

40	寬 4.0mm Width 4.0mm
48	寬 4.8mm Width 4.8mm
56	寬 5.6mm Width 5.6mm
60	寬 6.0mm Width 6.0mm
64	寬 6.4mm Width 6.4mm

4. 功能輔助件  
Options/Device

CF	三合一功能 "3 in 1" function
CE	埋壓拷克骨、立骨功能 Bulging type seams covering
AST	氣動式自動切線裝置 ( 有上切刀組 ) Pneumatic under & top thread trimmer
DS	直驅馬達 Direct-drive Servo Motor
EWT	電動式自動切線裝置 ( 無上切刀組 ) Electric automatic under thread trimmer
EST	電動式自動切線裝置 ( 有上切刀組 ) Electric automatic top & under thread trimmer
AWT	氣動式自動切線裝置 ( 無上切刀組 ) Pneumatic under thread trimmer
SM	伺服器馬達背掛式 Compact servo motor
CL	離合器馬達 Clutch motor

# SL-2800-356/SM

## 縱筒型三針五線雙面飾綳縫機

Feed-up-the-arm 3-needle 5-thread Interlock Machine with Compact Servo Motor for Needle Position and Auto Lifter



具備微型馬達設計  
縱筒加長型

*Long Arm!*



42cm (公分)



適用於各類袖、褲管折褲口、折下擺壓骨車縫  
Best-suited for stitch covering on long sleeves and trousers.

# SHING LING

INDUSTRIAL SEWING MACHINE

## SL-2800-356/SM/EST

### 縱筒加長型三針五線雙面飾綳縫機

Feed-up-the-arm 3-needle 5-thread Interlock Machine with Compact Servo Motor and Automatic Thread Trimmer

**Long Arm!**

**New**

具備  
微型馬達設計  
縱筒加長型



42cm (公分)



適用於各類袖、褲管折褲口、折下擺壓骨車縫  
Best-suited for stitch covering on long sleeves and trousers.



獨特粗細針按鈕設計可隨心所欲調整縫目粗細  
Stitch length can be adjusted quickly as required by the smart push-button.









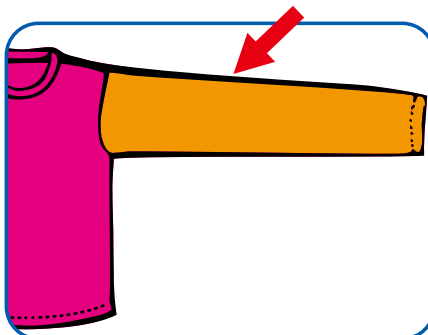

智慧型差動微調器可精密調整差動量  
Micro-adjustment regulator makes differential feed ratio easy and precise.



差動式送齒，無波浪縫製效果。  
Differential feed ratio design assures free from puckering



適用於各式休閒服折袖口、折下擺和各種針織品、運動服壓骨車縫。  
Applicable to stitch covering and hemming work on all kinds of small tubular knitwear, sportswear, T-shirts, underwear, etc.

									AVAILABLE DEVICE
SL-2800-356/SM/EST	2 3 4	4 5 6	4.0 4.8 5.6 6.4	1.5~5	2.5~5	6	9~11	3500	

# VG-999 Series

# SHING LING

INDUSTRIAL SEWING MACHINE

## 高速橫筒型三針五線雙面飾綳縫機

( 具備直驅微型馬達 . 自動切線等優良設計 )

High Speed 3-needle 5-thread Cylinder-bed Interlock Machine with Direct-drive Servo Motor, Top and Under Thread Trimmer



短筒設計 (47mm) , 易於操作 , 使車縫品質更好、更穩定。

Unique cylinder-bed (47 mm) shape ensures smooth flow of material and easy handling.



直驅式微型馬達 , 輕巧耐用。

Direct-drive servo motor makes sewing work stable and consistent.

## PERFORMANCE COMPARISON TABLE

VG999 - 3 56 - AST / RP

### 1. 機種 Model

VG999	高速橫筒型三針五線雙面飾綳縫機 High Speed 3-needle 5-thread Cylinder-bed Interlock Machine with Direct-drive Servo Motor, Top and Under Thread Trimmer
VG999-R500	三針五線環型鬆緊帶裝置 3-needle 5-thread Cylinder-bed Interlock Machine with Right-hand Fabric Trimmer
VG999-SB	三針五線短嘴型下座 3-needle 5-thread short Cylinder-bed type
VG999S-N700	細筒型三針五線雙面飾綳縫機 ( 附左修刀 ) 3-needle 5-needle Short Cylinder-bed Interlock Stitch Machine with Left-hand Knife Fabric Trimmer
VG999ES	超細筒型三針五線雙面飾綳縫機 Extremely Small Cylinder-bed Interlock Machine with Thread Trimmer
VG999-ZBR	高速橫筒型雙色飾線滾邊綳縫機 VG-999 Dual Colors Decorative Stitches with Top and Under Thread Trimmer and Direct-drive Servo Motor

### 2. 針數 No. of Needle

2	2 針 2 needles
3	3 針 3 needles
4	4 針 4 needles

### 3. 針寬 Needle Gauge

40	寬 4.0mm / Width 4.0mm
48	寬 4.8mm / Width 4.8mm
56	寬 5.6mm / Width 5.6mm
60	寬 6.0mm / Width 6.0mm
64	寬 6.4mm / Width 6.4mm

### 4. 功能輔助件 Options/Device

CF	三合一功能 ( 壓拷克骨、立骨、摺下擺、滾領 ) " 3 in 1 function" (Stitch covering, hemming and tape binding)
RP	後拖輪 ( 齒輪 ) Rear puller (teeth type)
RPA	後拖輪 ( 平輪 ) Rear puller (flat type)
EWT	電動式自動切線裝置 ( 無上切刀組 ) Electric automatic under thread trimmer
EST	電動式自動切線裝置 ( 有上切刀組 ) Electric automatic top & under thread trimmers
AWT	氣動式自動切線裝置 ( 無上切刀組 ) Pneumatic under thread trimmer
AST	氣動式自動切線裝置 ( 有上切刀組 ) Pneumatic top & under thread trimmer
DS	直驅馬達 Direct-drive servo motor
CS	氣動式密縫裝置 pneumatic condense stitch device

# VG-999 系列輔助件明細表

## VG-999 Series Options/Device

<p><b>DS</b> 直驅馬達 Direct-drive servo motor</p> 	<p><b>ME</b> 機電一體裝置</p> 	<p><b>AST</b> 氣動抬壓腳 Air type auto lifter</p> 	<p><b>EST</b> 電動抬壓腳 Electric auto lifter</p> 
<p><b>CF 三合一滾邊</b> 3 in 1 for Tape Binding</p> 	<p><b>CF 三合一折下擺及壓骨</b> 3 in 1 for Coverstitch &amp; hemming</p> 	<p><b>TF</b> 上送功能 Top feeder</p> 	<p><b>RP</b> 機械式後拖輪 Mechanic rear puller (Built-out type)</p> 
<p><b>CS</b> 密縫裝置 Condense stitch</p> 	<p>阻油裝置 Fully-sealed design</p> 	<p><b>VD</b> 吸布屑裝置 Pneumatic Venturi device</p> 	<p><b>RP</b> 後拖輪 (齒輪) Rear puller (teeth type)</p>  <p><b>RPA</b> 後拖輪 (平輪) Rear puller (rubber type)</p> 
<p><b>STF</b> 側送帶 Side Tape Feeder</p> 	<p><b>RB120</b> 吸風馬達 Electric venturi device</p> 	<p><b>AWT</b> 無上切刀 With air wiper</p> 	<p><b>EWT</b> 無上切刀 With electric wiper</p> 

## VG-999 系列特點

### Features of VG-999 series

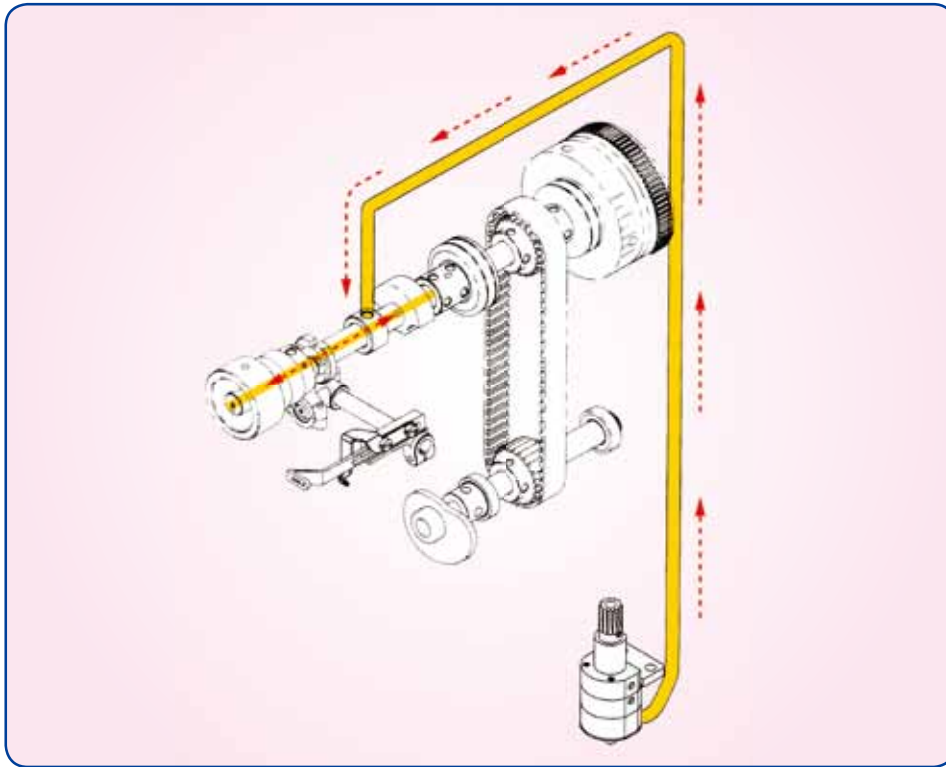

強制給油裝置  
Fully-automatic lubrication system

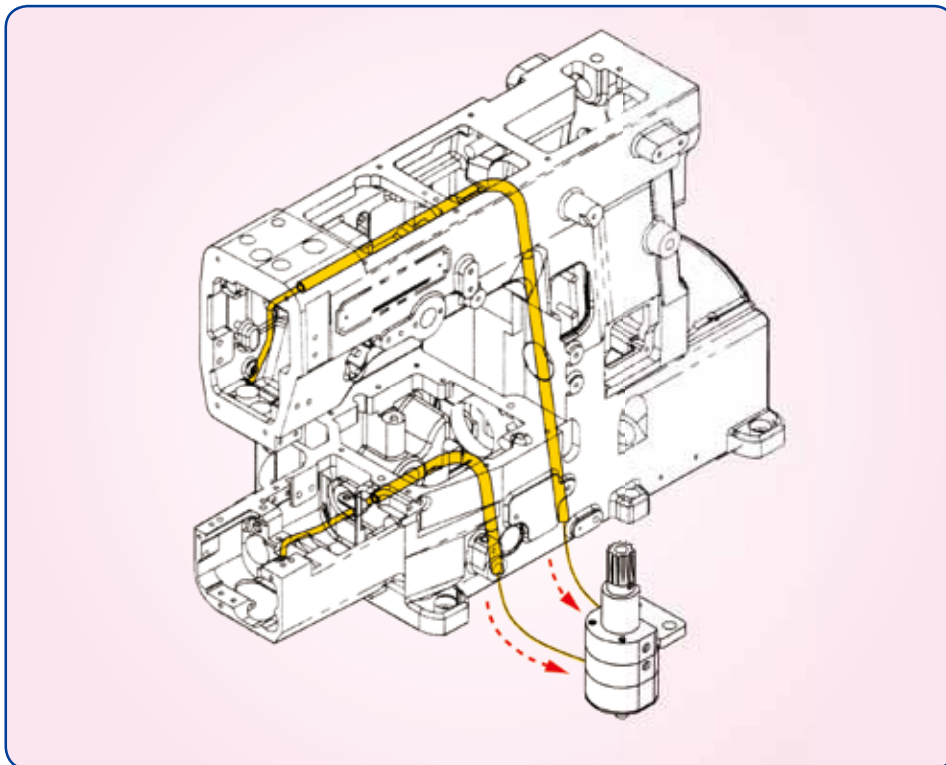

回收油裝置  
Recycling lubrication system



## VG-999 系列特點

### VG-999 Series Characteristics

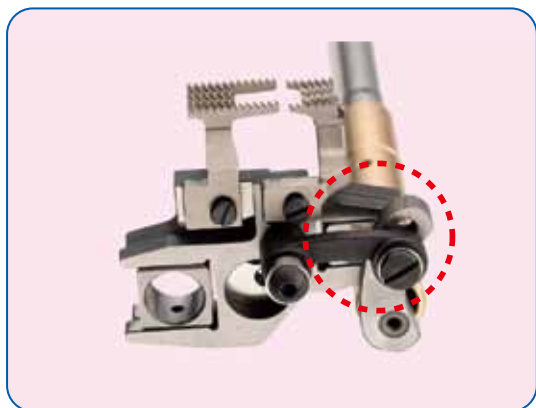

#### 兩段式差動更適合各種布料

Two-step differential feed ratio ensures superior sewing quality



#### 針棒行程31和33mm可變換薄厚車縫

Cam convertible to 31 and 33 mm is applicable to various production.

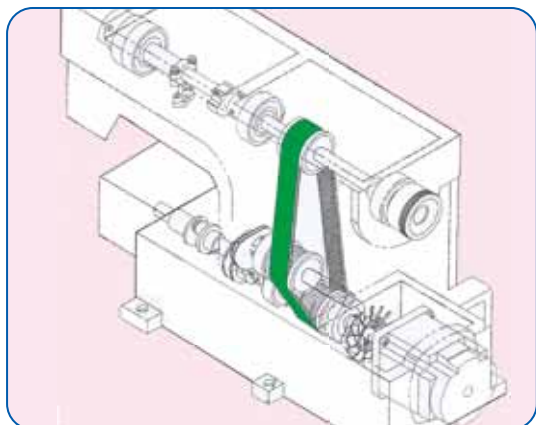

#### 單一傳動皮帶

##### Single Belt

單一皮帶同步帶動針棒，下勾針，凸輪傳動軸的獨創設計，除了節省耗材及傳動時零誤差且維修更方便。

Single belt can drive needle bar, looper shaft and take-up cam simultaneously. The state-of-the-art design is not only to save the power and material cost but easy for maintenance.

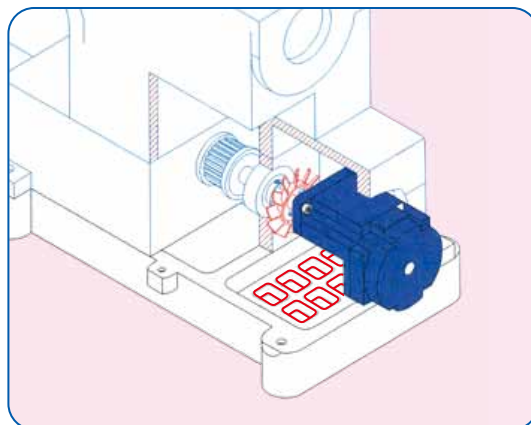

#### 獨創散熱裝置

##### Cutting-edge Cooling System

馬達環保節能散熱裝置

Green concept and power saving direct-drive servo motor.

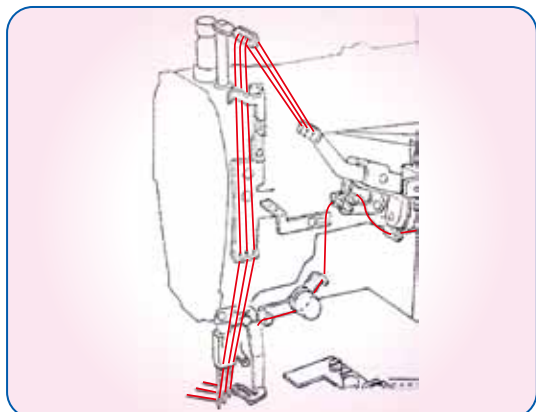

#### 標準穿法

Applicable to medium and heavy materials

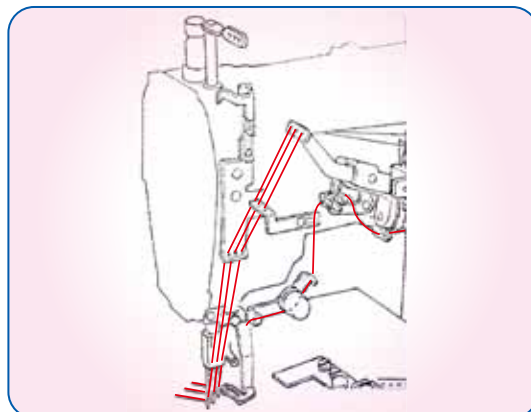

#### 薄料穿法

Applicable to soft and light materials

雙穿線功能，適合薄軟及一般布料的車縫  
Dual Seam threading is best suited to a wide selection of fabrics.

## VG-999 系列特點

### VG-999 Series Characteristics

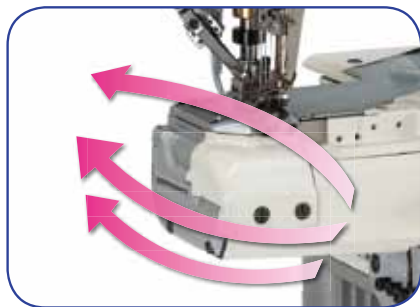

流線型機身設計，減少車縫布面阻力，順暢、快速

A streamline-shaped and shorter cylinder-bed design decreases sewing friction and increases sewing speed.



阻油功能 (一)  
針棒阻油裝置，有效防止油氣洩漏

Oil barrier to needle bar against oil splashes.



阻油功能 (二)  
下勾針棒阻油裝置，杜絕油氣漏出

Oil barrier looper bar against oil splashes.



阻油功能 (三)  
壓腳棒阻油裝置，杜絕油氣漏出

Fully sealed oil blocking design to presser foot system.



UTSL 功能 - 尾端打結收線

UTSL: Under thread stitch lock against raveling after cutting



分線器  
外置式打線凸輪，穿線簡單易調整、維修

Built-out looper take-up device is easy for threading and maintenance.

# VG-999-AST-DS

高速橫筒型三針五線雙面飾綳縫機  
(具備直驅微型馬達，自動切線等優良設計)

Cover Stitch, Hemming, Tape Binding  
壓骨、折下擺、滾邊 三合一

3 in 1



T-shirts



Polo shirts



滾邊 Tape Binding



壓骨 Stitch Covering

型號 MODEL	下刀裝置 Under trimmer	上刀裝置 Top trimmer	撥線裝置 Wiper	備註 Power
VG-999/AST	●	●		氣動 Air
VG-999/AWT	●		●	氣動 Air
VG-999EST	●	●		電動 Electric
VG-999/EWT	●		●	電動 Electric

Function		Spec.	UY128GAS								
基本縫 Seam Covering		3	5	5.6	1.4-3.6		1:0.6~1:2.1	6~8	5000	31/33	

# VG-999ES-AST-TF-DS

超細筒型三針五線雙面飾綳縫機 ( 附上送裝置 )  
 具備直驅微型馬達，自動切線等優良設計

Extremely Small Cylinder-bed Interlock Machine with Thread Trimmer and Top Feeder

**NEW**



標準筒圓周270mm  
 Circumference: 270mm



細筒圓周179mm  
 Circumference: 179mm



極細筒圓周112mm  
 Circumference: 112mm

# 小尺寸童裝

Good for Children wear



下擺 Hemming



壓骨 Cover Stitch



T-shirts

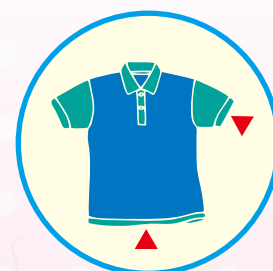

Polo shirts



壓骨  
Stitch Covering

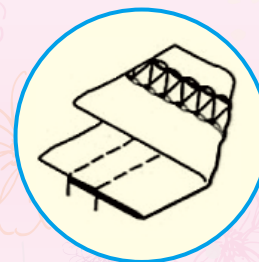

折下擺  
Hemming

型號 MODEL	下刀裝置 Under trimmer	上刀裝置 Top trimmer	撥線裝置 Wiper	備註 Power
VG-999ES/AST	●	●		氣動 Air
VG-999ES/AWT	●		●	氣動 Air
VG-999ES/EST	●	●		電動 Electric
VG-999ES/EWT	●		●	電動 Electric

Function		Spec.	UY128GAS						
折下擺 Hemming		2	4	4.0	0.8-3.3	1-5	4.5	2600	31/33
		2	4	4.8					
		3	5	5.6					
		3	5	6.4					
壓骨 Stitch Covering		2	4	4.0	0.8-3.3	1-5	4.5	2600	31/33
		2	4	4.8					
		3	5	5.6					
		3	5	6.4					

# VG-999S-N700-AST-TF-DS

細筒型三針五線雙面飾綳縫機 ( 附左修刀 . 上送裝置 )  
具備直驅微型馬達，自動切線等優良設計

3-needle 5-thread Small Cylinder Interlock Stitch  
Machine with Left-hand Knife Fabric Trimmer and Top Feeder



上送裝置  
Top Feeder



CS 密縫裝置  
CS: condense stitch



密縫樣式  
Sewn sample of condense stitch

**NEW**



型號 MODEL	下刀裝置 Under trimmer	上刀裝置 Top trimmer	撥線裝置 Wlper	備註 Power
VG-999S/N700/AST	●	●		氣動 Air
VG-999S/N700/AWT	●		●	氣動 Air
VG-999S/N700/EST	●	●		電動 Electric
VG-999S/N700/EWT	●		●	電動 Electric

Spec.		UY128GAS							
Function									
下擺縫製 Hemming		2 2 3 3	4 4 5 5	4.0 4.8 5.6 6.4	0.8-3.3	1-7	6	5000	31/33

# VG-999S-N700-AST-DS

細筒型三針五線雙面飾綳縫機 ( 附左修刀 )  
具備直驅微型馬達，自動切線等優良設計









3-needle 5-thread Small Cylinder Interlock Stitch  
Machine with Left-hand Knife Fabric Trimmer

**NEW**



標準型 Standard type  
Sleeve and bottom hemming

型號 MODEL	下刀裝置 Under trimmer	上刀裝置 Top trimmer	撥線裝置 Wlper	備註 Power
VG-999S/N700/AST	●	●		氣動 Air
VG-999S/N700/AWT	●		●	氣動 Air
VG-999S/N700/EST	●	●		電動 Electric
VG-999S/N700/EWT	●		●	電動 Electric

Spec.		UY128GAS							
Function				mm	mm		mm	mm	mm
下擺縫製 Hemming		2 2 3 3	4 4 5 5	4.0 4.8 5.6 6.4	0.8-3.3	1-7	6	4500	31/33



左修刀  
with left-hand knife



T-shirts

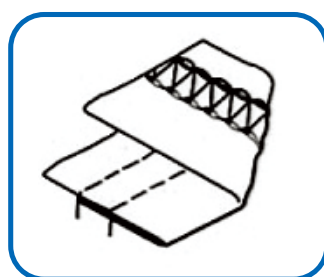

車縫方式  
sewn sample



Polo shirts

適用於：運動服袖口、下擺，伸縮性袖口、下擺  
圓筒狀衣物車縫作業，輕便縫製，全自動供油

Fully automatic lubrication design to the small cylinder-bed with left-hand knife fabric trimmer is best suited for any small tubular sleeve and bottom hemming work.

型號 MODEL	下刀裝置 Under trimmer	上刀裝置 Top trimmer	撥線裝置 Wlper	備註 Power
VG-999S/N700/AST	●	●		氣動 Air
VG-999S/N700/AWT	●		●	氣動 Air
VG-999S/N700/EST	●	●		電動 Electric
VG-999S/N700/EWT	●		●	電動 Electric

Spec.		UY128GAS							
Function									
下擺縫製 Hemming		2 2 3 3	4 4 5 5	4.0 4.8 5.6 6.4	0.8-3.3	1-7	6	5000	31/33



# VG-999-AST/EST/DS/CF/ZBR

## 高速橫筒型雙色飾線滾邊綉縫機

VG-999 Dual Colors Decorative Stitches with Top and Under Thread Trimmer and Direct-drive Servo Motor



滾邊加雙色線樣品  
Decorative stitch for tape binding



壓骨加雙色線樣品  
Decorative stitch for stitch covering

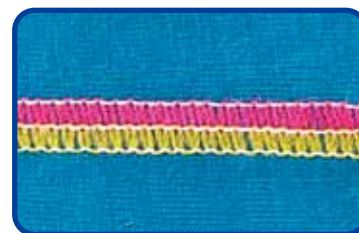

色線  
Stitch for tape binding

編織出

雙色壓骨

滾邊

折下擺

的彩色線條!

Fantastic two-color decorative stitches for  
Seam covering, tape binding and hemming.



T-shirts



Polo shirts

型號 MODEL	下刀裝置 Under trimmer	上刀裝置 Top trimmer	撥線裝置 Wiper	備註 Power
VG-999/AST/ZBR	●	●		氣動 Air
VG-999/AWT/ZBR	●		●	氣動 Air
VG-999/EST/ZBR	●	●		電動 Electric
VG-999/EWT/ZBR	●		●	電動 Electric

Function		Spec.	UY128GAS								
基本縫 Seam Covering		3	6	5.6	1.4-3.6		1:0.6~1:2.1	6~8	2500	31/33	

# VG-999-356/EST/ZBR/DS

## 高速橫筒型三針五線雙色上飾線綳縫機

High Speed 3-needle 5-thread Interlock Machine for Dual Colors  
Decorative Stitches with Top and Under Thread Trimmer and  
Direct-drive Servo Motor

<雙色標準型>

Regular Dual Colors Machine



T-shirts



Polo shirts



馬達環保節能散熱裝置  
Green concept and power  
saving direct-drive servo  
motor.



附氣動式/電動式上下切刀，使切  
線精準穩定

Neatly-finished Pneumatic/Electric  
Top and Under Thread Trimmer.



壓骨加雙色線樣品

Dual colors decorative  
stitches for seam covering.

# VG-999SB-AST/EST/DS

短筒型三針五線自動剪線、雙面飾綳縫機  
(具備直驅微型馬達、自動切線等優良設計)

3-needle 5-thread Short Cylinder-bed Interlock Stitch Machine with Direct-drive Sero Motor, Top and Under Thread Trimmer

專利 台灣 M348787.M348786  
號碼 日本特許第 4717920 號

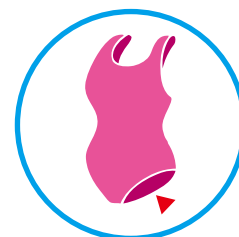
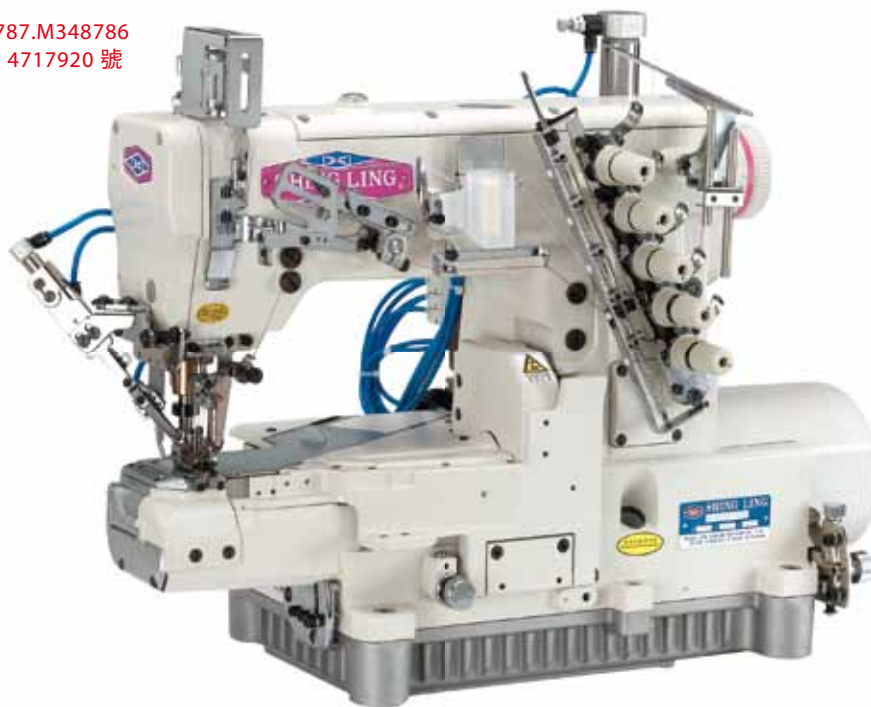

Swimwear

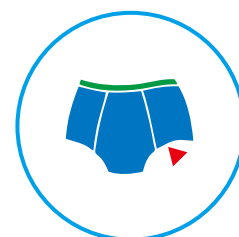

Briefs

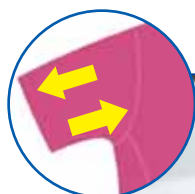

倒骨 Holding-down covering



立骨 Flatten-out covering



下擺 Bottom Hemming

型號 MODEL	下刀裝置 Under trimmer	上刀裝置 Top trimmer	撥線裝置 Wiper	備註 Power
VG-999/AST	●	●		氣動 Air
VG-999/AWT	●		●	氣動 Air
VG-999EST	●	●		電動 Electric
VG-999/EWT	●		●	電動 Electric

Function		Spec.	UY128GAS							
基本縫 Seam Covering		3	5	5.6	1.4-3.6		6-8	5000	31/33	

## VG-999-R500-AST-RP

### 高速橫筒型三針五線雙面飾綳縫機 (具備直驅微型馬達，自動切線等優良設計)

3-needle 5-thread Cylinder-bed Interlock Machine with Direct-drive Servo Motor, Top and Under Thread Trimmer (with Right-hand Knife Fabric Trimmer & Rear Puller)

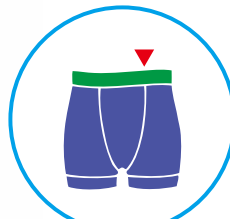
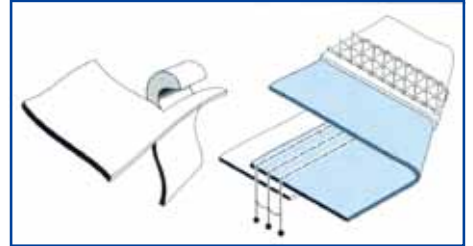

Boxer shorts



Briefs



**主要用途:** 男用內褲，褲頭鬆緊帶車縫。  
**Application:** Mainly for Men's brief & Boxer shorts

型號 MODEL	下刀裝置 Under trimmer	上刀裝置 Top trimmer	撥線裝置 Wlper	備註 Power
VG-999/AST	●	●		氣動 Air
VG-999/AWT	●		●	氣動 Air
VG-999EST	●	●		電動 Electric
VG-999/EWT	●		●	電動 Electric

Options 可選配	<b>RPA</b> Rear Puller (Rubber Type) 後拉輪(平輪)
<b>RP</b>	Rear Puller (Teeth Type) 後拉輪(齒輪)

吸布屑裝置建議為標準配備，若採用電動切線時需另外選購吸風馬達搭配，用來吸取布屑。

Fabric chip suction pipe & bag are standard equipment for this machine. If you choose EST type for thread trimming and presser foot lift, it is required to use a electric venturi device RB120 for waste fabric chips suction.











Spec.		UY128GAS								
Function				mm	mm		mm	mm	mm	mm
上鬆緊帶縫合 Elastic Waist-Band Attaching		3	5	5.6	1.4-3.6		1:0.6~1:2.1	6~8	3500	31/33

# VG898S-356-AST

## 高速細筒型三針五線綳縫機

3-needle 5-thread Cylinder-bed Interlock Machine with Direct-drive Servo Motor, Electric Top and Under Thread Trimmer











									AVAILABLE DEVICE
VG898S-356-AST	2 3 4	4 5 6	4.0 4.8 5.6 6.4	1.4~3.6	1:0.7 ~ 1:2.0	6	9~11	5000	AST/EST AWT/EWT DS/CL

# VG898A-356-AST

## 高速橫筒型三針五線綳縫機

3-needle 5-thread Cylinder-bed Interlock Machine with Direct-drive Servo Motor, Electric Top and Under Thread Trimmer



									AVAILABLE DEVICE
VG898A-356-AST	2 3 4	4 5 6	4.0 4.8 5.6 6.4	1.4~3.6	1:0.7 ~ 1:2.0	6	9~11	5000	AST/EST AWT/EWT DS/CL

# VG999-356-AST-CF-ZBR-DS-TKA

## 高速橫筒型雙色飾線滾邊綉縫機

VG-999 Dual Colors Decorative Stitches with Top and Under Thread Trimmer and Direct-drive Servo Motor



T-shirts



Polo shirts

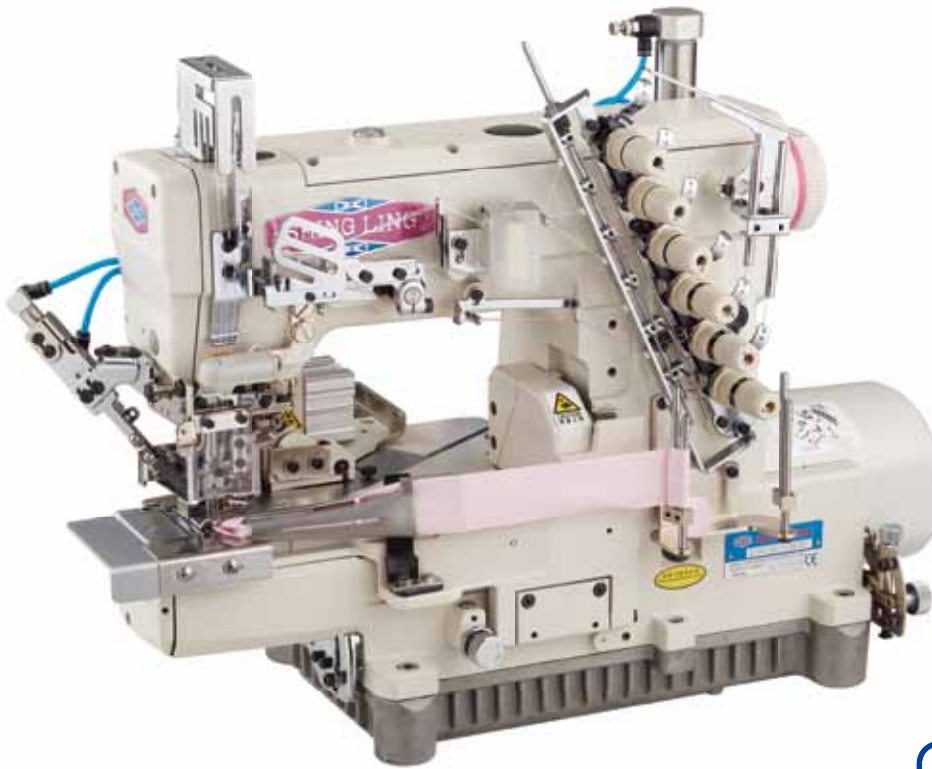

滾邊加雙色線樣品  
Decorative stitch for tape binding

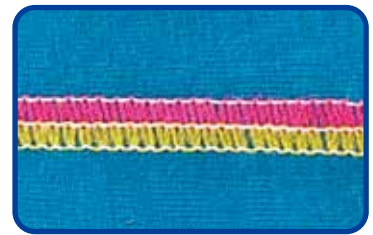

色線  
Stitch for tape binding



切刀圖

編織出

雙色壓骨

滾邊

折下擺

的彩色線條!

Fantastic two-color decorative stitches for Seam covering, tape binding and hemming.

型號 MODEL	下刀裝置 Under trimmer	上刀裝置 Top trimmer	撥線裝置 Wiper	備註 Power
VG-999/AST/ZBR/TKA	●	●		氣動 Air
VG-999/AWT/ZBR/TKA	●		●	氣動 Air
VG-999/EST/ZBR/TKA	●	●		電動 Electric
VG-999/EWT/ZBR/TKA	●		●	電動 Electric

Spec.		UY128GAS								
Function	基本縫 Seam Covering		3	6	5.6	1.4-3.6	1:0.6~1:2.1	6~8	2500	31/33

## VG-888A Series

### 高速橫筒型三針五線綳縫機

3-needle 5-thread Cylinder-bed Interlock Machine with Direct-drive Servo Motor, Electric Top and Under Thread Trimmer



專利精心設計，電動式切線刀組，各種角度調整簡便，切線時精準穩定。  
Newly-developed top and under thread trimmer can cut thread neatly and accurately.



									AVAILABLE DEVICE
VG-888A/AST	2 3 4	4 5 6	4.0 4.8 5.6 6.4	1.4~3.6	1:0.7 ? 1:2.0	6	9~11	4500	AST/EST AWT/EWT DS/CL

## PERFORMANCE COMPARISON TABLE

**VG-888A**

**3**

**56**

**AST**

**RP**

**DS**

### 1. 機種 Model

VG-888A	高速橫筒型三針五線綳縫機 3-needle 5-thread Cylinder-bed Interlock Machine with Compact Servo Motor, Electric Top and Under Thread Trimmer
VG-888A N600	三針五線左切刀修布邊裝置 Left-hand knife fabric trimmer
VG-888A -L200	三針五線環型伸縮帶車縫裝置 Elastic waist band attaching machine (manual type)
VG-888A -L300	三針五線自動環型伸縮帶車縫裝置 Elastic waist band attaching machine with pneumatic top and under thread trimmer
VG-888A-N600/TF/AST/SAH-II	三針五線左修刀修布裝置 / 上送 / 自動切線 / 自動折下擺器 Left-hand knife fabric trimmer/top feeder/thread trimmer/automatic hemming guide

### 2. 針數 No. of Needle

2	2 針 2 needles
3	3 針 3 needles
4	4 針 4 needles

### 3. 針寬 Needle Gauge

40	寬 4.0mm Width 4.0mm
48	寬 4.8mm Width 4.8mm
56	寬 5.6mm Width 5.6mm
60	寬 6.0mm Width 6.0mm
64	寬 6.4mm Width 6.4mm

### 4. 功能輔助件 Options/Device

CF	三合一功能 (壓拷克骨、立骨、摺下擺、滾領) "3 in 1 function" (Stitch covering, hemming and tape binding)
TF	上送布裝置 Top Feeder
WB	捲布吹平裝置 Uncurling Device
VDA	布屑集塵器 Venturi Device
RP	後拖輪 (齒輪) Rear puller (teeth type)
RPA	後拖輪 (平輪) Rear puller (rubber type)
EWT	電動式自動切線裝置 (無上切刀組) Electric automatic under thread trimmer
EST	電動式自動切線裝置 (有上切刀組) Electric automatic top & under thread trimmers
AWT	氣動式自動切線裝置 (無上切刀組) Pneumatic under thread trimmer
AST	氣動式自動切線裝置 (有上切刀組) Pneumatic top & under thread trimmer
DS	直驅馬達 Direct-drive servo motor

**VG-888A 系列輔助件明細表**  
VG-888A Series Options/Device

<p><b>DS</b> 直驅馬達 Direct-drive servo motor</p> 	<p><b>VD</b> 吸布屑裝置 Pneumatic Venturi device</p> 	<p><b>AST</b> 氣動抬壓腳 Air type auto lifter</p> 	<p><b>EST</b> 電動抬壓腳 Electric auto lifter</p> 
<p><b>CF</b> 三合一 3 in 1</p> 	<p><b>TF</b> 上送功能 Top feeder</p> 	<p><b>L200</b> 普通環形 Manual type</p> 	<p><b>L300</b> 氣動環形 Pneumatic type</p> 
<p><b>RP</b> 機械式後拖輪 Mechanic rear puller (Built-out type)</p> 	<p><b>RP</b> 後拖輪 (齒輪) Rear puller (teeth type)</p>  <p><b>RPA</b> 後拖輪 (平輪) Rear puller (rubber type)</p> 	<p><b>STF</b> 側送帶 Side Tape Feeder</p> 	<p><b>CS</b> 密縫樣式 Sewn sample of condense stitch</p> 
<p>阻油裝置 Fully-sealed design</p> 	<p><b>RB120</b> 吸風馬達 Electric venturi device</p> 	<p><b>AWT</b> 無上切刀 With air wiper</p> 	<p><b>EWT</b> 無上切刀 With electric wiper</p> 





以直驅馬達驅動抬壓腳及自動切線，操作更穩定簡便。

Stable auto lifter and thread trimmer driven by direct-drive servo motor.



省電直驅式馬達，不振動低噪音。

Direct-drive servo motor ensures power saving, less vibration and no noisy.



智慧型線圈調整裝置，使線圈可隨心所欲調整大小，符合多樣化車縫，品質完美之要求。

Smart loop adjuster makes size of needle loop at will.



專利設計全新改良，可調換之底線供給機構不易絞線。

Built-out looper take-up device is easy for threading and maintenance



改良式折下擺器，容易調整，車縫穩定、快速。

Improved hemming folder, easy adjustment, rapid and stable sewing are obtained.



調整式布誘導器、活動壓腳舌。

Adjusting fabric guide, and adjustable presser foot.



特殊改良設計。調節便利，使出線順暢穩定。

Patent-reserved under thread trimmer, easy adjustment, highly stable trimming, zero defect.



圓形粗細針縫目調整鈕，可在高速車縫進行中，隨心所欲精確地調整縫目長短。

Round-shaped regulator can precisely adjust the stitching length when machine is being operated.

Spec.		UY128GAS								
Function										
併縫 Attaching		3 3 4 4 4	5 5 6 6 6	5.6 6.4 5.2 6.0 6.4	1.4-3.6		1:0.7~1:2	6	4500	31
折下擺 Hemming		2 2 3 3	4 4 5 5	4.0 4.8 5.6 6.4	1.4-3.6		1:0.7~1:2	6	4500	31
喇叭滾邊 Tape Binding		2 2 3 3	4 4 5 5	4.0 4.8 5.6 6.4	1.4-3.6		1:0.7~1:2	6	4500	31
壓骨 Stitch Covering		2 2 3 3	4 4 5 5	4.0 4.8 5.6 6.4	1.4-3.6		1:0.7~1:2	6	4500	31

# SHING LING

INDUSTRIAL SEWING MACHINE

## VG-888A-N600/TF/AST/SAH-II

### 橫筒型三針五線雙面飾綳縫機 ( 附左修刀及上送裝置 )



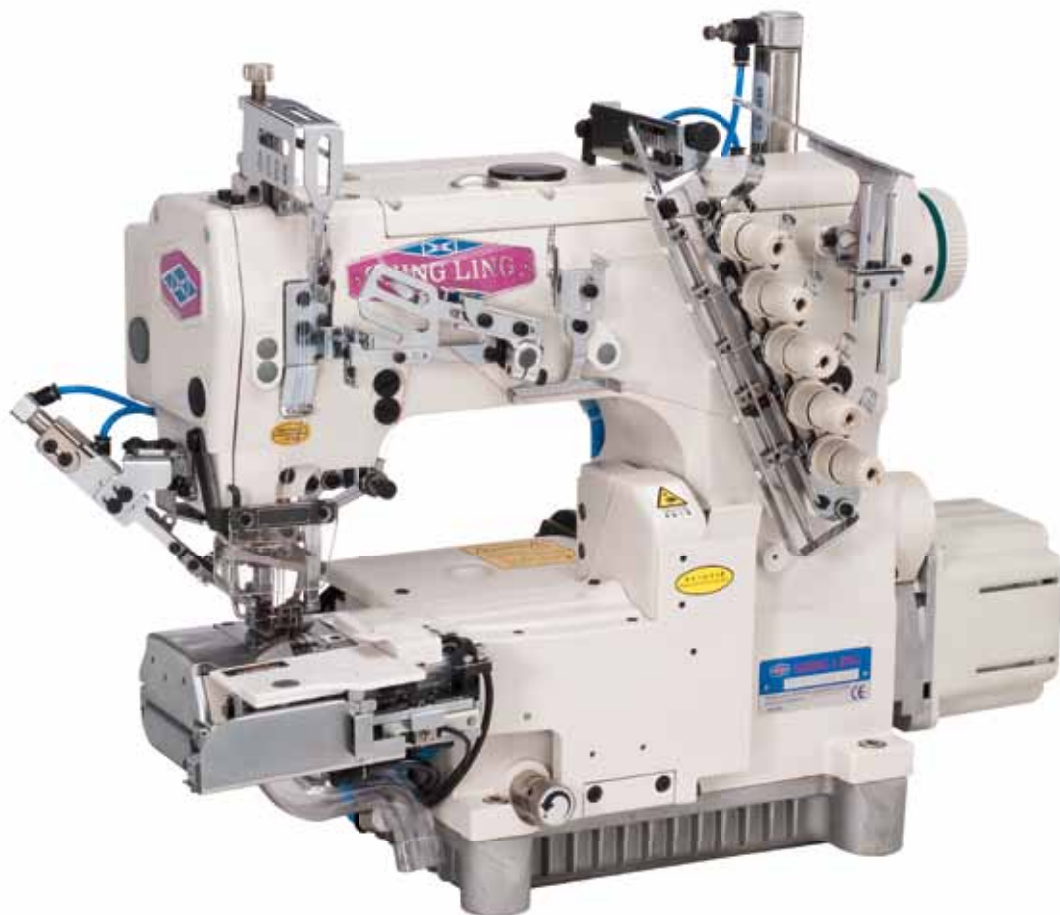





3-needle 5-thread Cylinder-bed Interlock Stitch Machine with Left-hand Knife Fabric Trimmer and Top Feeder



自動摺下擺車縫樣式  
Stitch sample of bottom hemming



自動摺下擺裝置 SAH-II  
Automatic hemming guide SAH-II

			 m.m.	 m.m.		 m.m.	 UT126AS TXZ	 S.P.M.	AVAILABLE DEVICE
VG-888A-N600/TF/ AST/SAH-II	2 3	4 5	4.0 4.8 5.6 6.4	1.4~3.6	1:0.7 ~ 1:2.0	6	9~11	4000	

# VG-888A-TF/AST

## 橫筒型三針五線雙面飾綳縫機 ( 附上送裝置 )









Top Feeder for 3-needle 5-thread Cylinder-bed Interlock Machine



橫筒型附上送裝置及自動切線，使壓骨及拷下擺車縫更平整美觀。

Equipped with top feeder and automatic top & under thread trimmer ensures perfect stitch covering and hemming work.



			 m.m.	 m.m.		 m.m.	 UN128GAS TXZT	 S.P.M.	AVAILABLE DEVICE
VG-888A-TF/AST	2 3 4	4 5 6	4.0 4.8 5.6 6.4	1.4~3.6	1:0.7 ? 1:2.0	6	9~11	4000	AST/EST AWT/EWT TF/DS/CL

# VG-888A-N600/AST

## 橫筒型三針五線雙面飾綳縫機









Interlock Machine with Left-hand Knife Fabric Trimmer for Hemming, Direct-drive Servo Motor, Tope and Under Thread Trimmer



左修刀及氣動式上下切刀  
(附切布屑吸風組)

Left-hand knife for a neatly-finished hemming work from soft & elastic to neatly-finished & steady seam (with venturi device)



			 m.m.	 m.m.		 m.m.	 UN128GAS TXZT	 S.P.M.	AVAILABLE DEVICE
VG-888A-N600/AST	2 3 4	4 5 6	4.0 4.8 5.6 6.4	1.4~3.6	1:0.7 ? 1:2.0	6	9~11	4000	AST/EST AWT/EWT DS/CL

# SHING LING

INDUSTRIAL SEWING MACHINE







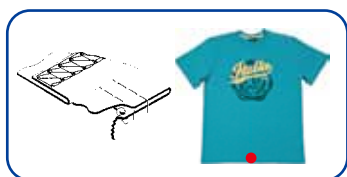

## VG-888A-N600-TF/AST (附左修刀裝置)

Top Feeder for Left-hand Knife Interlock Hemming Machine



左修刀附上送裝置及自動拷下擺，使車縫更平整，不起波紋。  
Left-hand knife hemming machine with top feeder receives a neat and free-from-puckering hemming work.



									AVAILABLE DEVICE
VG-888A-N600-TF/AST	2 3 4	4 5 6	4.0 4.8 5.6 6.4	1.4~3.6	1:0.7 ~ 1:2.0	6	UY128GAS TVA/	4000	AST/EST AWT/EWT TF/DS/CL

## VG-888A-CF Series 多功能筒型三針五線綑縫機

Cover Stitch, Hemming, Tape Binding

壓骨、折下擺、滾邊  
三合一

3 in 1



改良傳統型喇叭無法靠近機身，可隨心所欲上下左右調整喇叭座，另可裝喇叭2分到1英寸半特寬滾領及滾邊車縫喇叭。  
Improve the traditional binding device that can not approach body of the machine, our new design can adjust any directions at will to meet any binding sewing purpose. Finished size from 1/4"-1 1/2"











改良式折下擺器，容易調整，車縫穩定、快速。  
Improved hemming folder, easy adjustment, rapid and stable sewing are obtained.



調整式布誘導器、活動押腳舌。  
Adjusting fabric guide, and adjustable presser foot.



									AVAILABLE DEVICE
VG-888A-CF Series	2 3 4	4 5 6	4.0 4.8 5.6 6.4	1.4~3.6	1:0.7 ~ 1:2.0	6	UY128GAS TVA/	4500	AST/EST AWT/EWT RP/RPA DS/CL

# VG-888A-RP

## 後拉輪 (齒輪) 筒型三針五線綉縫機

Fitted with Rear Puller for Smooth Feeding Performance











送布齒與後拖輪完美的推送，使車縫中厚布料更順暢，進而達到高品質之要求。

Rear puller with feed dogs ensures a neat and uniform finish. Both teeth and rubber wheels are available.



Options 可選配	Function 功能	
RP	Rear Puller (Teeth Type) 後拉輪(齒輪)	RPA Rear Puller (Rubber Type) 後拉輪(平輪)

									AVAILABLE DEVICE
VG-888A-RP	2 3 4	4 5 6	4.0 4.8 5.6 6.4	1.4~3.6	1:0.7 ? 1:2.0	6	9~11	4000	AST/EST AWT/EWT RP/RPA DS/CL

# VG-888A-EST









3-needle 5-thread Cylinder-bed Interlock Machine  
with Direct-drive Motor, Electric Top and Under Thread Trimmer



專利精心設計，電動式切線刀組，各種角度調整簡便，切線時精準穩定。

Newly-developed top thread trimmer can cut threads at will neatly and accurately.



									AVAILABLE DEVICE
VG-888A-EST	2 2 3 3	4 4 5 5	4.0 4.8 5.6 6.4	1.4~3.6	1:0.7 ? 1:2.0	6	#10 #10 #11 #11	4500	AST/EST AWT/EWT DS

# SHING LING

INDUSTRIAL SEWING MACHINE

## VG-888A-L200

### 筒型棉織伸縮帶環縫機 (普通型)

Elastic Waist Band Attaching Machine (manual type)



普通型膝蓋開關式擴張滾輪組，操作簡便。









Manual type elastic band attaching by kneel switch



精密環狀鬆緊帶喇叭，確保縫目及線跡堅固美觀。

Accurate attaching folder ensures the sewing stitches consistent and uniform.



			 m.m.	 m.m.		 m.m.	 UN128GAS TXZT	 S.P.M	AVAILABLE DEVICE
VG-888A-L200	2 3	4 5	4.0 4.8 5.6 6.4	1.4~3.6	1:0.7 ? 1:2.0	5 5	#10 #11	4000	AST/EST

## VG-888A-L300/AST

### 筒型棉織伸縮帶環縫機 (自動切線)

Elastic Waist Band Attaching Machine with Pneumatic Top and Under Thread Trimmer











氣動式褲頭擴張滾輪組，使環狀鬆緊帶易於車縫上褲身。

Pneumatic extension puller gives a quick but accurate elastic band attaching work.



配合自動切線裝置，將大幅提高產能及品質。

Equipped with pneumatic (electric) top & under thread trimmer obtains good quality and higher productivity.

			 m.m.	 m.m.		 m.m.	 UN128GAS TXZT	 S.P.M	AVAILABLE DEVICE
VG-888A-L300/AST	2 3	4 5	4.0 4.8 5.6 6.4	1.4~3.6	1:0.7 ? 1:2.0	5 5	#10 #11	4000	AST/EST

## VG-888S Series

### 高速細筒型三針五線綳縫機

Small Cylinder-bed Interlock Machine with Direct-drive Servo Motor, Top and Under Thread Trimmer



“密封式側蓋設計”無任何漏油問題，而特殊短距橫筒設計，從側蓋到壓腳邊緣僅33mm，使綳縫作業更加順暢。

Thanks to "Fully-Sealed Side Cover" it assures free from oil leakage. Moreover, shorten distance from side cover to presser foot by 33mm enable to meet sewing work at ease and will.

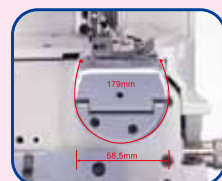

精巧迷你型細筒圓周179mm的設計，可任意車縫小口徑的圓筒型針織布，流暢美觀。

The compact-size cylinder bed minimized the circumference at 179mm can sew any small-size tubular knitwear more conveniently.



專利設計微調式差動調整，可精密調整差動進給量。

Patent-reserved design the differential feed ratio level makes the ratio adjustment stable and precise.

## PERFORMANCE COMPARISON TABLE

VG-888S

3

56

AST

RP

### 1. 機種 Model

VG-888S

高速細筒型三針五線綳縫機  
Small Cylinder-bed Interlock Machine with Compact Servo Motor, Top and Under Thread Trimmer

### 2. 針數 No. of Needle

2 2 針  
2 needles

3 3 針  
3 needles

4 4 針  
4 needles

### 3. 針寬 Needle Gauge

40 寬 4.0mm  
Width 4.0mm

48 寬 4.8mm  
Width 4.8mm

56 寬 5.6mm  
Width 5.6mm

60 寬 6.0mm  
Width 6.0mm

64 寬 6.4mm  
Width 6.4mm

### 4. 功能輔助件 Options/Device

CF 三合一功能  
(壓拷克骨、立骨、摺下擺、滾領)  
"3 in 1 function" (Stitch covering, hemming and tape binding)

TF 上送布裝置  
Top feeder

RP 後拖輪 (齒輪)  
Rear puller (teeth type)

RPA 後拖輪 (平輪)  
Rear puller (rubber type)

EWT 電動式自動切線裝置 (無上切刀組)  
Electric automatic under thread trimmer

EST 電動式自動切線裝置 (有上切刀組)  
Electric automatic top & under thread trimmers

AWT 氣動式自動切線裝置 (無上切刀組)  
Pneumatic under thread trimmer

AST 氣動式自動切線裝置 (有上切刀組)  
Pneumatic top & under thread trimmer

DS 直驅馬達  
Direct-drive servo motor

## 888S 系列輔助件明細表

### 888S Series Options/Device

<p><b>DS</b> 直驅馬達 Direct-drive servo motor</p> 	<p><b>VD</b> 吸布屑裝置 Pneumatic venturi device</p> 	<p><b>AST</b> 氣動抬壓腳 Air type auto lifter</p> 	<p><b>EST</b> 電動抬壓腳 Electric type auto lifter</p> 
<p><b>RP</b> 機械式後拖輪 Mechanic rear puller</p> 	<p><b>RP</b> 後拖輪 (齒輪) Rear puller (teeth type)</p> 	<p><b>RPA</b> 後拖輪 (平輪) Rear puller (rubber type)</p> 	<p><b>STF</b> 側送帶 Side Tape Feeder</p> 
<p><b>CS</b> 密縫樣式 Sewn sample of condense stitch</p> 	<p><b>CS</b> 密縫裝置 Condense stitch device</p> 	<p>阻油裝置 Fully-sealed oil blocking design</p> 	<p>回油裝置 Fully-automatic lubrication</p> 
<p><b>RB120</b> 吸風馬達 Electric venturi device</p> 	<p><b>TF</b> 上送功能 Top feeder</p> 	<p><b>AWT</b> 無上切刀 with air wiper</p> 	<p><b>EWT</b> 無上切刀 with electric wiper</p> 



## VG-888S/AST 細筒型三針五線綉縫機

Small Cylinder-bed Interlock Machine with Direct-drive Servo Motor, Pneumatic Top and Under Thread Trimmer



“密封式側蓋設計”無任何漏油問題，而特殊短距橫筒設計，從側蓋到壓腳邊緣僅33mm，使綉縫作業更加順暢。

Thanks to "Fully-Sealed Side Cover" it assures free from oil leakage. Moreover, shorten distance from side cover to presser foot by 33mm enable to meet sewing work at ease and will.

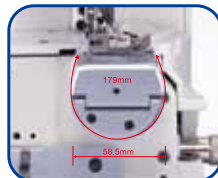









精巧迷你型細筒圓周179mm的設計，可任意車縫小口徑的圓筒型針織布，流暢美觀。

The compact-size cylinder bed minimized the circumference at 179mm can sew any small-size tubular knitwear more conveniently.



專利設計微調式差動調整，可精密調整差動進給量。

Patent-reserved design the differential feed ratio level makes the ratio adjustment stable and precise.

									AVAILABLE DEVICE
VG-888S/AST	2 2.2 3 3.4	4 4.4 5 5.6 6	4.0 4.8 5.6 6.4	1.4~3.6	1:0.7 ? 1:2.0	6	9~11	4000	AST/EST AWT/EWT DS

## VG-888S/EST 細筒型三針五線綉縫機









Small Cylinder-bed Interlock Machine with Direct-drive Servo Motor, Electric Top and Under Thread Trimmer



自動切線設計電動式上下切刀組，下刀快速精準，切線俐落，低噪音且調整容易。

Electric automatic top & under thread trimmers, trims precisely and stably, reduce sound and easy to adjust.



									AVAILABLE DEVICE
VG-888S/EST	2 2.2 3 3.4	4 4.4 5 5.6 6	4.0 4.8 5.6 6.4	1.4~3.6	1:0.7 ? 1:2.0	6	9~11	4000	AST/EST AWT/EWT DS

# SHING LING

INDUSTRIAL SEWING MACHINE

## VG-888S-RP

### 後拉輪 (齒輪) 細筒型三針五線綑縫機









Fitted with rear puller.  
Both teeth & rubber type are available.



細筒型搭配齒型後拖輪，使中厚布料壓骨及拷下擺車縫平整美觀。

Small cylinder bed with rear puller achieves a smooth feed performance on stitch covering and hemming work.



									AVAILABLE DEVICE
VG-888S-RP	2 2 3 3 4	4 4 5 5 6	4.0 4.8 5.6 6.4	1.4~3.6	1:0.7 ? 1:2.0	6	UV126GAS TXXZ 4	4000	AST/EST AWT/EWT RP/RPA/DS

## VG-888S-TF/AST Series

### 細筒型三針五線雙面飾綑縫機 (附上送裝置)

Top Feeder for Small Cylinder-bed Interlock Machine



細筒型附上送裝置，使任何小直徑管狀袖口到長距離壓骨及拷下擺車縫更順暢美觀。

Small cylinder bed equipped with top feeder is best-suited to stitch covering on small tubular cuff, long-distance bottom hemming regardless of light to heavy weight materials.



									AVAILABLE DEVICE
VG-888S-TF/AST Series	3 3 4	4 4 5 5 6	4.0 4.8 5.6 6.4	1.4~3.6	1:0.7 ? 1:2.0	6	UV126GAS TXXZ 4	4000	AST/EST AWT/EWT DS/TF



最精準上送機構

The most accurate top feeder.



精密刻度設計，能快速且精準調整上送差動速率。

Accurate graduation can precisely adjust the top feed ratio.



上送機構與過線裝置

Top feeder and eyelet system & dual seam technology.



可調式拷下擺器能隨意調整寬度

Adjustable folder for any width of hemming work.



以直驅馬達驅動抬壓腳及自動切線，操作更穩定簡便。

Stable auto lifter and thread trimmer driven by direct-drive servo motor.



省電直驅式馬達，不振動、低噪音。

Direct-drive servo motor ensures power saving, less vibration and no noisy.

Function		Spec.	UY128GAS									
併縫 Attaching			3	5	5.6				1:0.7~1:2			
			3	5	6.4					6	4000	31
			4	6	5.2	1.4-3.6						
			4	6	6.0							
折下擺 Hemming			2	4	4.0				1:0.7~1:2			
			2	4	4.8					6	4000	31
			3	5	5.6	1.4-3.6						
			3	5	6.4							
喇叭滾邊 Tape Binding			2	4	4.0				1:0.7~1:2			
			2	4	4.8					6	4000	31
			3	5	5.6	1.4-3.6						
			3	5	6.4							
壓骨 Stitch Covering			2	4	4.0				1:0.7~1:2			
			2	4	4.8					6	4000	31
			3	5	5.6	1.4-3.6						
			3	5	6.4							

## FG-666 Series

### 平床型三針五線雙面飾綳縫機 (自動切線)

3-needle 5-thread Flat-bed Interlock Machine with Top and Under Thread Trimmer



高速耐磨傳動齒輪皮帶，確保長久使用。  
High speed transmission gear and belt with long-life durability.



專利精心設計，電動式切線刀組，各種角度調整簡便，切線時精準穩定。  
Newly-developed top thread trimmer can cut threads neatly and accurately.

## PERFORMANCE COMPARISON TABLE

FG-666

3

56

FQ

AST

### 1. 機種 Model

FG-666	平床型三針五線雙面飾綳縫機 (自動切線) 3-needle 5-thread Flat-bed Interlock machine with thread trimmer.
FG-797	三針五線滾領機 3-needle 5-thread Flat-bed Interlock machine with tape binder.
FG-798	三針五線普通車 3-needle 5-thread Flat-bed Interlock machine.
FG-799	三針五線右修刀蕾絲綳縫機 Right hand knife fabric trimmer

### 2. 針數 No. of Needle

2	2 針 2 needles
3	3 針 3 needles
4	4 針 4 needles

### 3. 針寬 Needle Gauge

40	寬 4.0mm Width 4.0mm
48	寬 4.8mm Width 4.8mm
56	寬 5.6mm Width 5.6mm
60	寬 6.0mm Width 6.0mm
64	寬 6.4mm Width 6.4mm

### 4. 功能輔助件 Options/Device

FQ	三合一功能 (壓拷克骨、立骨、摺下擺、滾領) "3 in 1 function" (Stitch covering, hemming and tape binding)
EWT	電動式自動切線裝置 (無上切刀組) Electric automatic under thread trimmer
EST	電動式自動切線裝置 (有上切刀組) Electric automatic top & under thread trimmers
AWT	氣動式自動切線裝置 (無上切刀組) Pneumatic under thread trimmer
AST	氣動式自動切線裝置 (有上切刀組) Pneumatic top & under thread trimmer
TKA	氣動切刀 Pneumatic tape cutter
TKE	電動切刀 Electric tape cutter
264	2 針貼條裝置 2-needle 2-looper tape attaching



專利設計下切線刀組，穩定性高，不易故障，調整簡便。

Patent-reserved under thread trimmer receives a superior high quality sewing work.



專利設計全新改良，可調換之底線供給機構不易絞線。

Newly-developed looper take-up device to ensure the looper thread free from winding.



專利設計及全新改良之可調換之底線供給機構，不易絞線，凸輪更換簡便，降低故障率。

Patent-reserved looper thread take-up device, free thread winding and easy for cam replacement. No breakdown is guaranteed.



隨機附輔助配件，使特殊布料之壓骨作業方便容易。(壓骨)

Equipped with fabric guide and plate for easy and effective operation on any seam covering. (Cover Stitch)



滾條切刀組可完美搭配高速三本車滾邊作業。

Accurate Tape Cutter ensures neatly-finished cutting.



智慧型線圈調整裝置，使線圈可隨心所欲調整大小，符合多樣化車縫，品質完美之要求。

Smart loop adjuster makes precisely size of needle loop at will.

Function		Spec.	UY128GAS							
併縫 Attaching		3	5	5.6	1.4-3.6		1:0.7~1:2	6	4500	31
		3	5	6.4						
		4	6	5.2						
		4	6	6.0						
折下擺 Hemming		2	4	4.0	1.4-3.6		1:0.7~1:2	6	4500	31
		2	4	4.8						
		3	5	5.6						
		3	5	6.4						
喇叭滾邊 Tape Binding		2	4	4.0	1.4-3.6		1:0.7~1:2	6	4500	31
		2	4	4.8						
		3	5	5.6						
		3	5	6.4						
壓骨 Stitch Covering		2	4	4.0	1.4-3.6		1:0.7~1:2	6	4500	31
		2	4	4.8						
		3	5	5.6						
		3	5	6.4						

# FG-666/EST

## 平床型三針五線雙面飾綉縫機 (自動切線)

3-needle 5-thread Flat-bed Interlock Machine with Top and Under Thread Trimmer



高速耐磨傳動齒輪皮帶，確保長久使用。  
High speed transmission gear and belt with long-life durability.



專利精心設計，電動式切線刀組，各種角度調整簡便，切線時精準穩定。  
Newly-developed top thread trimmer can cut threads neatly and accurately.

									AVAILABLE DEVICE
FG-666/EST	3 3 4	4 5 6	4.0 4.8 5.6 6.4	1.4~3.6	1:0.7 ? 1:2.0	6	UV128GAS TXZT	4500	AST/EST AWT/EWT

# FG-666-264-SL 雙勾針鏈目縫貼條機

2-needle 2-looper Double Chainstitch for Tape Attaching



雙勾針鏈目縫貼條機  
2-needle 2-looper double chainstitch machine with vertical folder for tape attaching.



適用於各式休閒服接肩及領口的壓條車縫  
Suitable for tape binding on opening of neck and shoulder of T-shirts and Sportswear.



									AVAILABLE DEVICE
FG-666-264-SL	2	4	6.4	1.4~3.6	1:0.7 ? 1:2.0	8	UV128GAS TXZT	2500	AST/EST STF

# FG-666-FQ Series 多功能平床型三針五線綑縫機

Cover Stitch, Hemming, Tape Binding  
壓骨、折下擺、滾邊 三合一

3 in 1



隨機附輔助配件，使特殊布料之壓骨作業方便容易。(壓骨)

Equipped with fabric guide and plate for easy and effective operation on any seam covering.(Cover Stitch)



改良式折下擺器，容易調整，車縫穩定快速。(折下擺)









Improved hemming folder, easy adjustment, rapid and stable sewing are obtained.(Hemming)



改良傳統型喇叭無法靠近機身，可隨心所欲上下左右調整喇叭座，另可裝喇叭2分到1英寸半特寬滾領及滾邊車縫喇叭。

Improve the traditional binding device that can not approach body of the machine, our new design can adjust any directions at will to meet any binding sewing purpose. Finished size from 1/4"-1 1/2"



									AVAILABLE DEVICE
FG-666-FQ Series	3 3 4	4 5 6	4.0 4.8 5.6 6.4	1.4~3.6	1:0.7 ? 1:2.0	6	9~11	4000	TKE TKA STF

# FG-797 平床型三針五線滾領機

High Speed Flat-bed 3-needle 5-thread Interlock Machine



裝備改良型喇叭，使滾邊作業快速容易。亦可更換配件，做一般綑縫，拷下擺，壓骨等作業。









Tape binder is easily adjusted to ensure smooth and fasttape binding operation. The model can be easily converted into standard needle gauge for hemming, stitch covering, and 4-needle for two fabrics attaching.



特殊設計無段式單鈕獨控，可任意調整縫目長度。

Stepless adjustments by the one push button. Changing stitch length is easy. A push button stopper is applied to prevent careless changes to the stitch length.



									AVAILABLE DEVICE
FG-797	3 3 4	4 5 6	4.0 4.8 5.6 6.4	1.4~3.6	1:0.7 ? 1:2.0	6	9~11	4000	STF

# FG-798-TF-SAS

## 平床型三針五線袖口、下擺綳縫機 ( 附上送裝置 )

Automatic Interlock Machine with Variable Top Feeder for Hemming Flat Sleeves and Bottoms



全自動袖口摺邊控制器，以伺服器馬達驅動，是高品質、高產能的機種。  
The integrated sewing unit with servo motor is applicable to high productivity of hemming flat sleeves and bottoms of T-shirt, underwear and similar garments.



袖口送布裝置可調整大小。最大寬幅為 1 1/4"，即使是新手也能簡單操作，使效率提高數倍。  
Thanks to the adjustable guide for hemming width max. 1 1/4 inches, the operator simply places the fabric and the unit automatically performs the hemming operations, thereby providing uniform and quality production.



雙向穿線機構可應用於多樣布種及鬆緊線下擺、袖口等綳縫作業。  
Dual Seam technology is to make soft-seam for ladies shorts, boxer pants and well-tense seam is best-suited for jackets, polo T-shirts, etc.

									AVAILABLE DEVICE
FG-798-TF-SAS	2 2 3 3	4 4 5 5	4.0 4.8 5.6 6.4	1.4~3.6	1:0.7 ? 1:2.0	6	9~11	3000	

# FG-799 平床型三針五線雙面飾綳縫機附右切刀修布裝置

3-needle 5-thread Flat-bed Interlock Machine with Right-hand Knife Fabric Trimmer



具機械式送料裝置，可將鬆緊帶或蕾絲帶之送料量及張力，控制得均勻而準確。  
With mechanical upper metering device, tension and feeding amount of elastic tape or lace can be controlled evenly and accurately.



右修刀切布裝置及微調式送帶裝置  
Right-hand Knife with Micro-adjust mechanism Metering Device.



STF 側送帶  
Side Tape Feeder



									AVAILABLE DEVICE
FG-799	2 2 3 3	4 4 5 5	4.0 4.8 5.6 6.4	1.4~3.6	1:0.7 ? 1:2.0	6	9~11	3000	



## SL-1790

## 高速電子平頭鎖眼機

Computer-controlled High-speed Lockstitch Buttonholing Machine



- 具備彩色液晶觸控式的新型操作控制盤。  
User-friendly colorful control panel is our unique design.
- 附有急停裝置，車縫行進中可即行停車。  
Employed urgent breaking system, the machine can be stopped while it is running.



## 短壓腳 Short Presser Foot



工作範圍 :25m/m  
Operating:25m/m

## 中壓腳 Middle Presser Foot



工作範圍 :35m/m  
Operating:35m/m

## 長壓腳 Long Presser Foot































































工作範圍 :120m/m  
Operating:120m/m

## 針織壓腳 The Presser Foot For Knits



## 標準縫製型式一覽表

### SL-1790 Standard Sewing Shape List

(1) Square type 角型  PANEL DISPLAY 液晶顯示  1	(2) Round type 圓型  PANEL DISPLAY 液晶顯示  2	(3) Radial square type 輻射角型  PANEL DISPLAY 液晶顯示  3	(4) Radial type 輻射型  PANEL DISPLAY 液晶顯示  4	(5) Radial straight bartacking type 輻射直線加固型  PANEL DISPLAY 液晶顯示  5	(6) Radial taper bartacking type 輻射錐形加固型  PANEL DISPLAY 液晶顯示  6
(7) Eyelet square type 圓頭扣眼角型  PANEL DISPLAY 液晶顯示  7	(8) Eyelet radial type 圓頭扣眼輻射型  PANEL DISPLAY 液晶顯示  8	(9) Eyelet straight bartacking type 圓頭扣眼直線加速型  PANEL DISPLAY 液晶顯示  9	(10) Eyelet taper bartacking type 圓頭扣眼錐形加速型  PANEL DISPLAY 液晶顯示  10	(11) Semilunar type 半月型  PANEL DISPLAY 液晶顯示  11	(12) Round square type 圓角型  PANEL DISPLAY 液晶顯示  12
(18) Semilunar square type 半月角型  PANEL DISPLAY 液晶顯示  13	(14) Semilunar straight bartacking type 半月直線加固型  PANEL DISPLAY 液晶顯示  14	(15) Semilunar taper bartacking type 半月錐形加固型  PANEL DISPLAY 液晶顯示  15	(16) Eyelet semilunar type 圓頭扣眼半月型  PANEL DISPLAY 液晶顯示  16	(17) Eyelet round type 圓頭扣眼圓形  PANEL DISPLAY 液晶顯示  17	(18) Square radial type 角輻射型  PANEL DISPLAY 液晶顯示  18
(19) Square semilunar type 角半月型  PANEL DISPLAY 液晶顯示  19	(20) Square round type 角圓型  PANEL DISPLAY 液晶顯示  20	(21) Square straight bartacking type 角直線加固型  PANEL DISPLAY 液晶顯示  21	(22) Square taper bartacking type 角錐型加固型  PANEL DISPLAY 液晶顯示  22	(23) Radial semilunar type 輻射半月型  PANEL DISPLAY 液晶顯示  23	(24) Radial round type 輻射圓形  PANEL DISPLAY 液晶顯示  24
(25) Semilunar radial type 半月輻射型  PANEL DISPLAY 液晶顯示  25	(26) Semilunar round type 半月圓形  PANEL DISPLAY 液晶顯示  26	(27) Bar-tacking 加固型  PANEL DISPLAY 液晶顯示  27	(28) Bar-tacking, right cut 加固右切斷  PANEL DISPLAY 液晶顯示  28	(29) Bar-tacking, left cut 加固左切斷  PANEL DISPLAY 液晶顯示  29	(30) Bar-tacking, center cut 加固中央切斷  PANEL DISPLAY 液晶顯示  30

## 規格 Specifications

機種名稱	SL-1790
縫製速度 Sewing speed	最高 :4,200 R.P.M.、常用 3,600 R.P.M. Max. 4,200 R.P.M., Normal 3,600 R.P.M. 使用無供油旋梭時 (選購件) 最高 :3,300 R.P.M. When the non-lubricated hook (optional) is used: 3,300 R.P.M.
針杆行程 Needle bar stroke	34.6mm
切布切刀尺寸 Size of cloth cutting knife	6.4mm ~ 31.8mm (1/4" ~ 1-1/4")
套結寬度 Bartacking width	最大 5mm (選購件 :6mm、特別規格零件 : 最大 10mm) Max. 5.0mm (with special-specification part: Max. 10mm)
鎖眼縫製長度 Buttonhole length	最大 41mm (選購件 :70mm、120mm) Max. 41mm (optional: 70mm, 120mm)
面線張力 Needle thread tension	電子夾線器 (電子線張力機構) Active tension (electronic thread tension control system)
針數 Number of stitches	根據鎖眼尺寸、縫距能自動計算 Automatically computed from the size of the buttonhole and stitch pitch
機針 Needle	DP×5(#11J)#11J ~ #14J
旋梭 Hook	DP 型全回轉旋梭 DP type, full-rotary hook 無供油旋梭 (選購件) Non-lubricated hook (optional)
壓腳上升量 Lift of the work clamp	14mm (反轉抬針時 17mm) 14mm (17mm when the reverse-rotation needle-up function is used)
自動抬壓腳裝置 Auto-lifter	標準型配件 (脈衝方式) Provided as standard (stepping motor type)
擺針驅動方式 Needle throwing system	脈衝馬達驅動 Stepping motor
送布驅動方式 Cloth feeding system	通過脈衝馬達間歇送布 Intermittent feed by stepping motor
切布切刀驅動方式 Cloth cutting knife system	電磁鐵往返驅動 By double-acting solenoid
標準花樣數 Number of standard patterns	30 個花樣 30 patterns
可儲存資料量 Number of patterns that can be input	最大 99 個花樣 99 patterns
卷底線裝置 Bobbin thread winder	縫紉機頭部內置式 Built-in the machine head
縫紉機頭驅動方式 Machine head drive system	小型 AC 伺服馬達 (直接驅動方式) Compact AC servo motor (direct-drive system)
供油方式 Lubrication	僅限旋梭部微量供油 Only the hook section needs a minimum-quantity lubrication.

# SL-1905A-SS

## 全自動直驅式高速電子雙用機

Automatic Direct-drive Type High Speed Computer Controlled Double Function Machine.



# SL-1900 series

## 高速電子套結車、釘扣車

High speed computer-controlled bartacking, and button sewing machine

## PERFORMANCE COMPARISON TABLE



### 1. 機種 Model

SL-1905A-SS	全自動直驅式高速電子雙用機 Automatic Direct-drive Type High Speed Computer Controlled Double Function Machine.
-------------	--

### 2. 機型車縫功能 Sewing function

1900A	套結 bartacking
1903A	釘扣 button sewing

### 3. 型式車縫布料 Type Sewing material

薄	Light material
中厚	Standard material
厚	Heavy material

## 特點

Characteristics

- SL-1900A 最高操作速度 3000 轉 / 分，SL-1903A 最高操作速度 2700 轉 / 分。  
The real max. operation speed of SL-1900A is 3000 rpm/min. The real max. operation speed of SL-1903A is 2700 rpm/min.
- 「微油式」潤滑系統，針棒、跳線桿、前蓋部份無機油潤滑，解決漏油困擾。  
Thanks to the design of Micro-lubrication system, so that the needle bar, thread take-up, and front cover do not require any lubrication to prevent from the oil leakage problem.
- 簡化型操作面板，省略循環按鍵，直接挑選調整項目，簡單、快速尋找所需功能。  
Simplified control panel design leaves out the 「Selection」 key, it can pick up the adjusting item directly and find the needed functions fast and simply.
- 一次循環車縫可執行達 25 種不同的車縫花樣。  
This machine provides max. 25 different stitches in one cycle sewing operation.

## SL-1900A-SS

### 全自動直驅式高速電子套結機

SL-1900A-SS Computer-controlled  
Direct-drive High-speed Bartacking Machine.



智慧型自動偵測織物厚薄感知系統，最高實際操作速度可達 3,000 轉 / 分，微油式滑潤系統，簡化型面板，一次循環縫紉可執行多達 25 種不同的車縫花樣。

Automatic detected function for the fabric thickness, micro-lubrication system, simplified control panel, the machine can offer max. 25 different bartacking stitches in a cycle seam operation.

## SL-1903A

### 全自動直驅式高速電子平縫釘釦機

SL-1903A Computer-controlled  
Direct-drive High-speed Button Seam

特點：  
僅需加購一組配件及記憶晶片。即可記憶於同一機台上，將打結 (1900) 功能釘釦 (1903) 功能，互相更換！一機雙功能，大幅節省成本！

FEATURE:  
Simply buying an extra set of accessory and chip, you can easily exchange the bar tacking (1900) and button seam (1903) function in the same machine. ONE machine TWO practical functions save great deal of your cost.



## 直驅式高速包縫機

Direct-drive High-speed Overlock Sewing Machine



### ■ 技術特色

包縫機的一種新型機器，本機速度可調，自動停針，自動剪線，可以準確無誤的保證機器在任何時候都停在上針位，高速高效，定位準確，使用方便。

### ■ PRIMARY CHARACTERISTIC

Characterist: it is the product of mechanical-electronical integration, in tegrating with ecact mechanism and computer technology, and also It is the new model that direct drive technology applying on high-speed overlock sewing machine. It is function includes automatic thread ceasing, automatic thread cutting, and independent designed special controller, which accurately ensures ceasing on needle position anytime, cutting thread at any moment, it has been welcomed by clients because of it is good effect. More than 10 extended models available on this series.

			 mm		 mm	 mm				
BML-8800D-4	DPx27 11#	2	6	4	4	3.6	0.7-2	6000	470x330x480	25.5/33

# 直驅式高速全自動包縫機

## Direct-drive High-speed Automatic Overlock Sewing Machine



### 技術特色











本機採用內置式直驅電機，具有全人工、半自動、全自動三種模式可供用戶選擇；具有自動抬壓腳、自動起步、自動縫紉、自動停車、自動剪線功能；具有廢料吸收式集塵裝置；HR 硅油裝置；最高轉速可達 8000 轉 / 分鐘。

本機是新一代節能、高效、環保型超高速包縫機的代表產品，省電 60% 以上同時提高生產效率 30% 以上，該系列機型適用於針織內衣，薄中厚料服裝及皮革製品等。

### PRIMARY CHARACTERISTIC

Adopts built-in direct drive motor, with full manual, semi-automatic, fully automatic three modes for the user to choose; with automatic presser foot, automatic start, automatic sewing, automatic stop, automatic thread trimmer function; with a dust collecting device waste absorption; HR silicone oil device; the highest speed up to 8000 Rev / min...

New generation of energy-saving, efficient, environmentally friendly products on behalf of super speed overlock sewing machine, saving over 60% at the same time, improve production efficiency more than 30%, this series of machines are suitable for knitting nuderwear, thin to medium thick garments and leather products.

										
BML-8800T-4	DPx27 11#	2	5.5	4	0.6-3.8	4	0.7-2	7500	470x330x480	25.5/33

## 包縫機輔助件 Overlock Stitch Machine Options/Device

### VD 吸布屑裝置

Pneumatic venturi device



### 拷克布樣

Overlock Stitch sample



## SL-9500-D3 直驅式單針自動切線平縫機

Direct drive high speed one needle lockstitch sewing machine



## ■ 技術特色

採用內置式直驅伺服馬達，實現了機器的快速啟動和制動的精確度；大幅降低了噪音和震動，並降低了能耗，與普通的驅動裝置相比，電量耗減35%以上，具有自動剪線、撥線、倒縫等功能，使操作更加簡單、方便，大大提高工作效率，與普通平縫機相比，生產效率提高15%以上，投入使用二年所節約的工作資源即可收回機器投入資本。

## PRIMARY CHARACTERISTIC

Using the built-in direct drive servo motor, realizes computer quick start and brake precision; greatly reduces the noise and vibration, and reduces the energy consumption, and the ordinary driving device, power consumption of more than 35%, with automatic thread trimmer, shifting lines, backstitch function, make operation more simple, convenient, greatly improves the work efficiency, and ordinary lockstitch sewing machine, production efficiency is improved by more than 15%, put into use two years of the saving work resources to recover the machine into capital.

機型	單針	針距	壓高	下送	迴針	剪線	中寬	中厚	平床校	特性	箱盆	淨重
SL-900II	DBx1	0-5	5.5-13	★	★	★	★	★	★	5000	625x250x550	33/38

## SL-8800-997 / 998 折景花樣車 (普通型)

SL-8800 Pleating(Ruffling) Machine



規格→4針-工字摺  
Specification: Four needle-H-shaped pleating(ruffling)  
用途:適用跳舞裝、禮服、窗簾、飾品等範圍  
Applicable to dance clothing, formal dress, curtains and accessory etc.

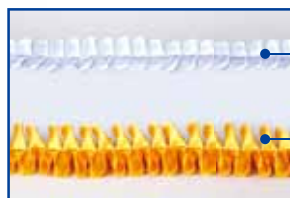

**SL-A997 單折花樣**  
Single Pleating(Ruffling) Pattern

**SL-A998 雙折花樣**  
Double Pleating(Ruffling) pattern

A997型 單折花樣  
Single Pleating(Ruffling) Pattern

花盤規格	折景裝置-A997型 Pleating(ruffling) device-A997 花盤→1針單折 (3m/m) Pattern_cam → One needle single pleating(ruffling)
	型號→4針單折 (12m/m) Model→Four needle single pleating(ruffling) →6針單折 (18m/m) Six needle single pleating(ruffling)

A998型 雙折花樣  
Double Pleating(Ruffling) pattern

花盤規格	折景裝置-A998型 Pleating(ruffling) device-A998 單針雙折 Single needle double pleating(ruffling) 4針折一次 Four needle for one pleating(ruffling)

機器型號 Machine model	用針 Needle	線X2 Thread X2	適用範圍 Application	轉速 s.p.m work speed s.p.m)
SL-8800	DBx1#9-11		薄料 Light fabric	1000





**VG-999ES-AST-TF-DS**  
Extremely-Small Cylinder-bed Interlock  
Machine with Thread Trimmer and Top Feeder  
超細筒型三針五線雙面飾綉縫機



**VG-999S-N700-AST-TF-DS**  
Small Cylinder-bed Interlock Machine with  
Left-hand Knife and Top Feeder for Hemming  
細筒型三針五線雙面飾綉縫機 (附左修刀)



**VG-888A-N600-TF/AST**  
Interlock Machine with Left-hand Knife  
and Thread Trimmer for Hemming  
橫筒型附左修刀雙面飾綉縫機



**VG-999-SB-AST/EST-DS**  
High-speed Short Cylinder-bed Interlock  
Machine with Thread Trimmer  
短筒型三針五線雙面飾綉縫機



**VG-999-R500-AST-RP**  
Interlock Machine with Right-hand Knife and  
Rear Puller for Elastic Waistband Attaching  
高速橫筒型三針五線附右修刀雙面飾綉縫機



**VG-999-356/EST/DS/ZBR**  
Dual Colors Decorative Stitches Interlock  
Machine with Top and Under Thread Trimmer  
高速橫筒型三針五線雙色上飾綉縫機



**SL-703P-G3-452/460**  
4-needle 6-thread Feed-off-the-arm Interlock  
Flatseaming Machine (Fully-enclosed type)  
手臂型四針六線併縫機 (附雙差動送布齒裝置)



**SL-2800-356/SM**  
Feed-up-the-arm Interlock Machine with  
Compact Servo Motor and Thread Trimmer  
縱筒型三針五線雙面飾綉縫機



**SL-2700-AST/EST**  
Feed-up-the-arm Interlock Machine with  
Compact Servo Motor and Thread Trimmer  
縱筒型三針五線雙面飾綉縫機



**VG-888S-TF-AST**  
Small Cylinder-bed Interlock Machine  
with Thread Trimmer and Top Feeder  
細筒型三針五線雙面飾綉縫機 (附上送裝置)



**VG-999-AST/EST-DS-CF-ZBR**  
Dual colors decorative stitches  
Machine for tape binding  
高速橫筒型雙色飾綉滾邊綉縫機

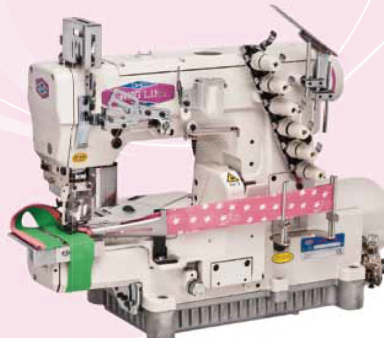

**SL-1790S**  
Computer-controlled High-speed  
Lockstitch Buttonholing Machine  
高速電子平頭鎖眼機



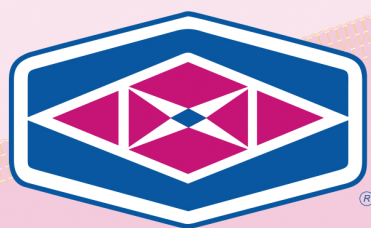

SHING LING<sup>®</sup>



星菱縫機股份有限公司

SHING LING SEWING MACHINE CO., LTD.

※本目錄所記載的規格式樣或外觀，因加以改良，有時不預告即加以變更，請見諒。  
The specifications in this catalog are subject to change without notifications.



CE ISO 9001/CNS 12681 2017.01

經銷商/AGENT